

CEMINTEL[®]

DESIGN AND INSTALLATION GUIDE



INTRODUCTION

TABLE OF CONTENTS

01 INTRODUCTION	2	Corrosivity Categories	21
Introduction	2	Other Design Considerations	21
02 PRODUCT OVERVIEW	3	05 COMPONENTS + ACCESSORIES	22
Panel Information	4	06 SYSTEM ENGINEERING	27
Product Specifications	4	Design, Detailing and Performance	
Colour Palette	5	Responsibilities	28
03 SYSTEM OVERVIEW	6	Spacing of Horizontal H515 Top Hats	30
Pressure Equalised Ventilated		ExpressWall and Intermediate Top Hat	
Cavity System	7	Spacings	31
Sealant Filled Joints	8	Panel Fixing Requirements	32
Applications	9	Fire, Acoustic & Thermal Solutions	33
Benefits of the Cemintel's Surround External		07 INSTALLATION	38
Panels on the ExpressWall Fixing		Prior to Installation	39
System	9	Installation Set-Out	40
System Solutions	9	Installation for Timber and Steel Framing	40
04 DESIGN + AESTHETIC		Procedure for Installation of	
CONSIDERATIONS	10	Cemintel Rigid Air Barrier	46
General	11	Procedure for Installation of	
Panel Appearance & Finish	11	Soft Air Barriers	48
Panel Layout	12	08 CONSTRUCTION DRAWINGS	
Structural	12	+ DETAILS	50
Top Hats	14	09 SAFETY, HANDLING + GENERAL CARE	64
Pre-Drilling Panel Holes	14	Health, Safety and PPE	65
Face Fixings	14	Handling & General Care	65
Window & Door Openings	15	10 WARRANTY, CLEANING	
Eaves Junctions	15	+ MAINTENANCE	66
Control Joints	15	Warranty	67
Moisture Management	16	Wash Down Process	67
Insulation and Energy Efficiency	17	Inspection, Repair and Maintenance	67
Climate Zones for Thermal Design	19		
Fire Performance	20		
Extreme Climate Conditions	20		

Introduction

Cemintel's Surround walling system combines a prefinished surface with a simple installation system that can be used for residential and commercial buildings.

This Design and Installation Guide recommends good building practice methodology and has been prepared as a general guide of design considerations, system engineering information and installation procedures for common external applications. It assumes that the user has an intermediate knowledge level of building design and construction. In no way does it replace the services of the building professionals required to design projects, nor is it an

exhaustive guide of all possible scenarios. It is the responsibility of the architect, designer and various engineering parties to ensure that the details in this Design and Installation Guide are appropriate for the intended application.

Surround can be installed either horizontally or vertically, externally or internally. This guide refers to **external installations** only as components differ depending on the installation.

Refer to the 'Design and Installation Guide for Cemintel Surround Internal Installation' for instructions regarding internal applications.



PRODUCT OVERVIEW

Panel Information

Cemintel Surround panels are prefinished, fibre cement panels that are colour bodied delivering a more natural appearance and depth of colour than can be achieved with a standard surface painted finish. They come trimmed and sealed in a standard 1200 x 3000 x 8mm size*.

Consisting primarily of Portland Cement, wood pulp, reinforcement fibres, air and water, panels have undergone a longer, natural air curing process and offer superior performance in terms of strength, density and durability, making them an excellent choice for commercial applications subject to higher wind loads.

The range comprises 5 colour groups. Each group has a foundation 'Base' colour and 4 complementary textures/patterns featuring a matte finish. There is also a 'Secondary' palette with colours that work across each range. Panels come with a range of colour matched rivets to provide a more seamless aesthetic finish.

Panels feature a UV protective coating applied during the manufacturing process. Rain water washes contaminants away entailing minimal maintenance, ongoing good looks and superior durability.

*Lengths up to 3050mm are available as special orders.

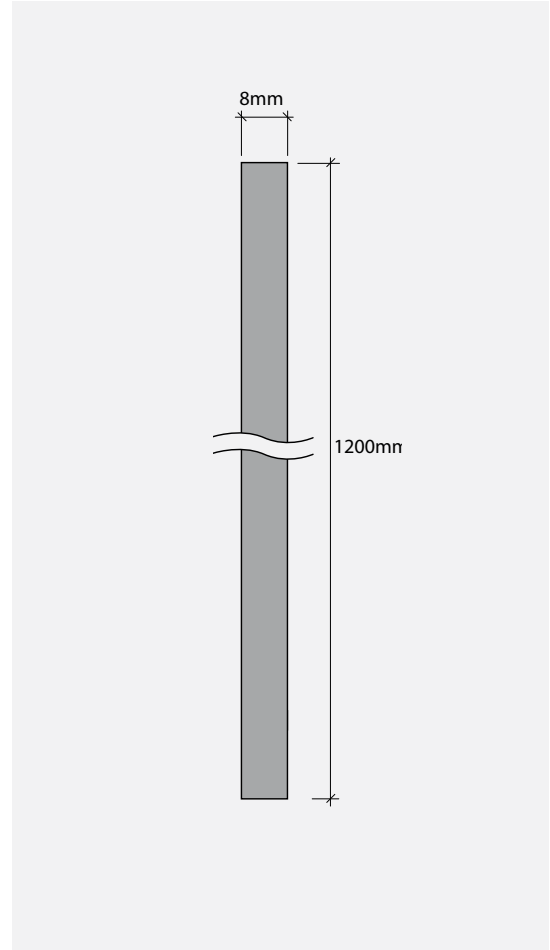

Product Specifications/System Solutions

A technical Data Sheet can be downloaded from cemintel.com.au

Dimensional/Geometrical Characteristic	Specification (trimmed panel)	Manufacturing Tolerance	Relevant Standard
Panel Width	1200mm	+ / - 1.5mm	EN 12467
Panel Length	3000mm*	+ / - 1.5mm	EN 12467
Panel Thickness	8mm	+ / - 0.8mm	EN 12467
Panel Mass (EMC)	15.7kg/m ²		



Colour Palette

As Surround is a prefinished product, product images may vary from the actual product in regard to colour and surface finish.

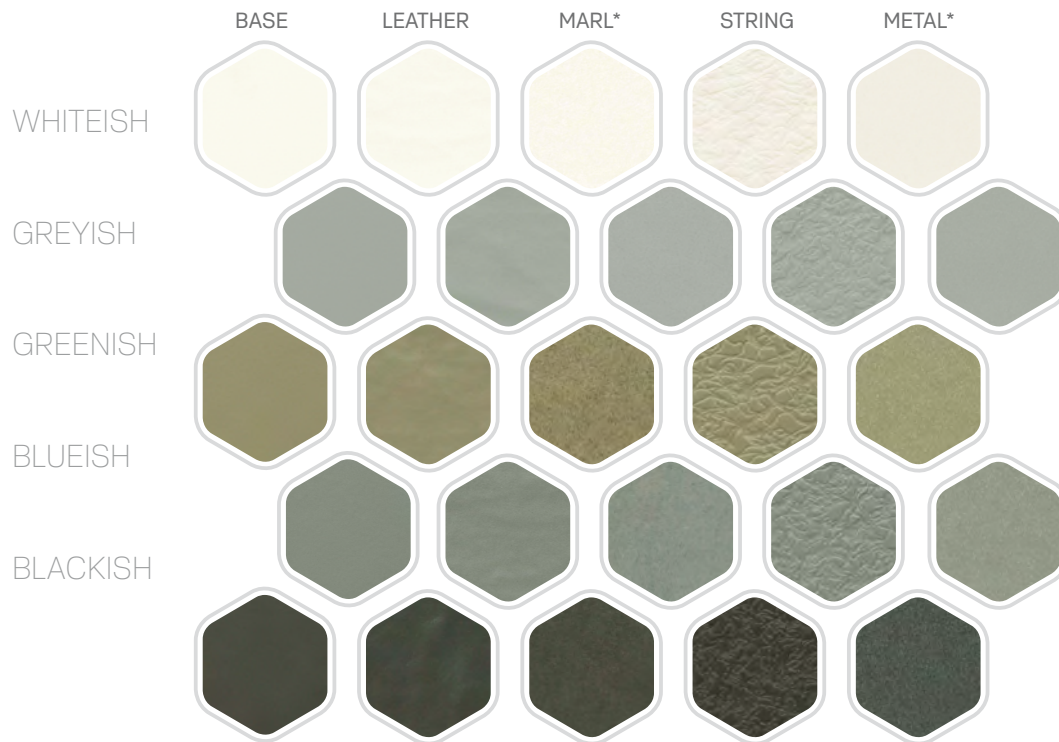

*Non-stocked item. Minimum order quantities and lead times apply.



#Limited stock held otherwise minimum order quantities and lead times apply.

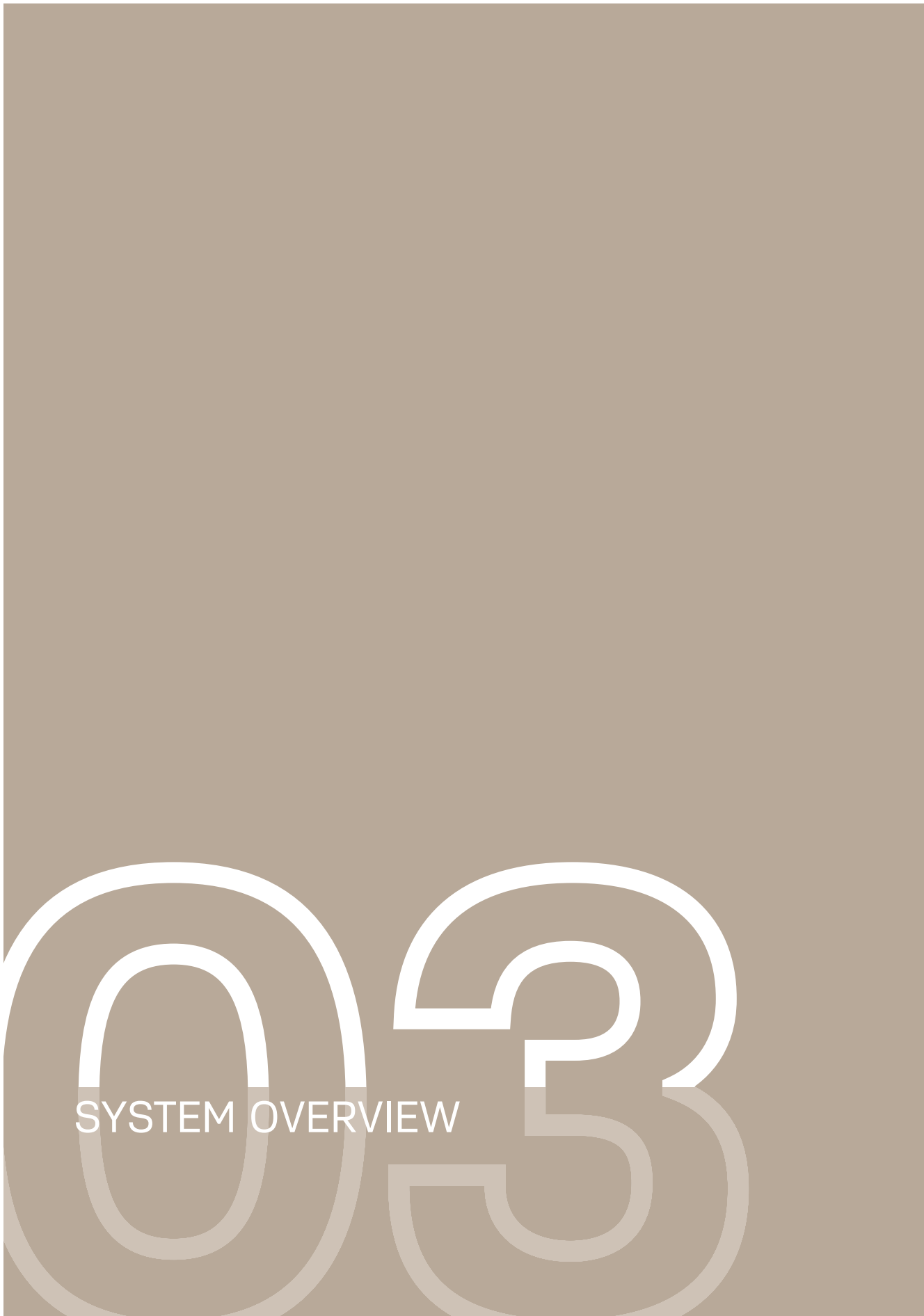

SYSTEM OVERVIEW

SYSTEM OVERVIEW



Cemintel Surround panels are pre-drilled and then fixed onto supporting metal top hats using unique, colour matched, stainless steel rivets.

The Surround system uses only one rivet type which allows a subtle “sliding” movement across the panel. This reduces the complexity of installation and reduces the stresses created where panels are installed with rigid “fixed” points.

Panels are installed to give an express jointed appearance. A vertical gasket tape is placed on the vertical top hat to provide added weather resistance and an angled backing strip is placed at horizontal joints to encourage water run-off.

Pressure Equalised Ventilated Cavity System

Cemintel Surround External panels can be installed horizontally or vertically onto steel or timber stud framing or masonry/concrete using the proven and versatile Commercial ExpressWall® top hat fixing system. The ExpressWall system provides a versatile and durable façade which is suitable for an extensive range of building types. Panels are pre-drilled and then fixed with expressed joints to vertical metal top hats using Surround rivets. A vertical gasket tape is placed on the top hat to provide added weather resistance, and a backing

strip is used at horizontal joints to reduce water ingress.

Panels are installed as a pressure equalised ventilated cavity system which is easy to install and delivers a high weather performance system. In certain conditions, eg. higher corrosive zones, there is the option of sealing joints and header to reduce the circulation of air behind the façade.

This manual provides information on both systems.

Cemintel Surround is installed over an air barrier onto ExpressWall™ top hats using Surround rivets. This creates a pressure equalised cavity system which enhances weather resistance.

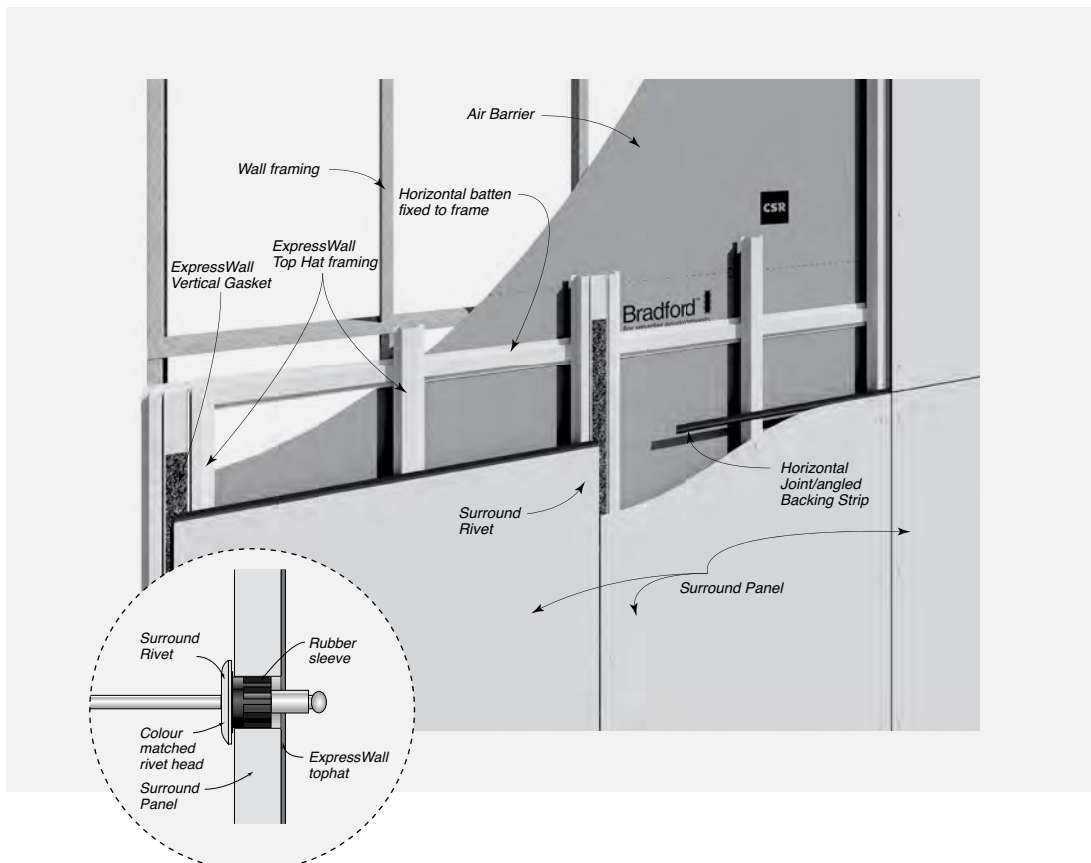

03

SYSTEM OVERVIEW

Typical Surround System Cross Section
for Steel Framing

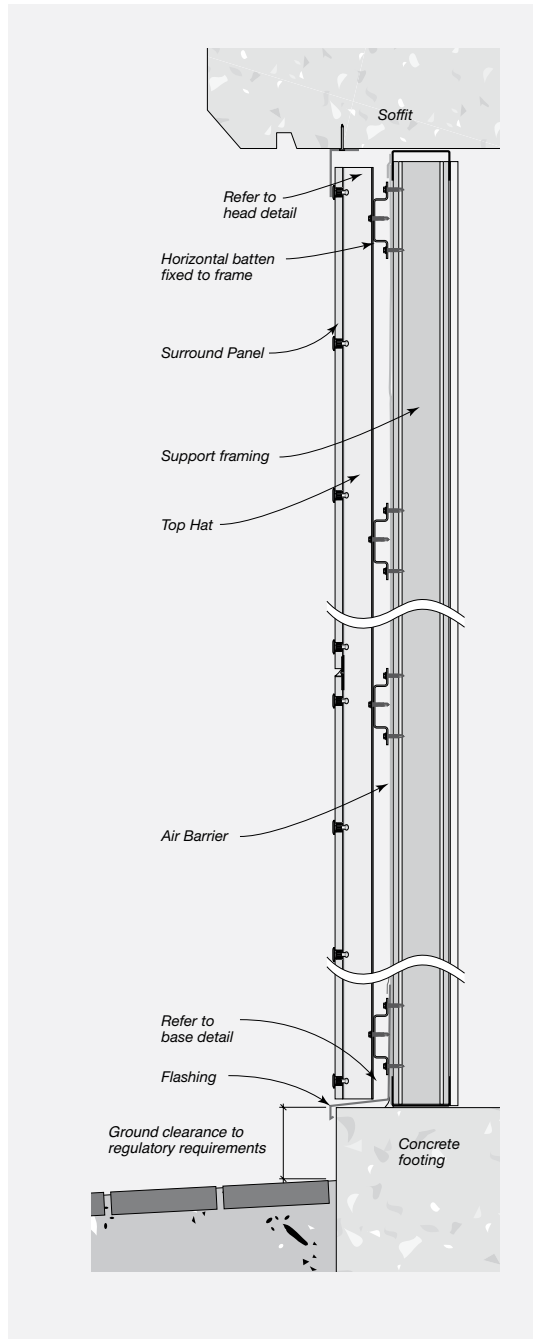

In a pressure equalised system, a cavity is formed between an air barrier and the façade. Openings around the base and top of the façade allow pressure equalisation, and create the drying benefits of air circulation and drainage. This system reduces the risk of moisture penetration and prevents moisture build up, allowing the building shell to dry out, creating a healthier, more breathable building.

Panels are installed to give an express jointed appearance. A vertical gasket tape is placed on the vertical top hat and a metal backing strip is placed at horizontal joints. Horizontal joints at base of wall and at inter-storey junctions are left open to maintain a ventilated cavity and to allow for moisture drainage.

The air barrier may consist of a wall wrap or rigid materials such as fibre cement, metal sheet, or masonry. The installation of Bradford wall wraps and Cemintel Rigid Air Barrier as air barriers are detailed in the Cemintel Air Barrier Design and Installation Guide. Other wall wraps and sheet materials must be installed in accordance with manufacturer's instructions.

Masonry and concrete substrates must be sealed to act as an air barrier for an effective waterproofing system.

Sealant Filled Joints

In some applications, or for aesthetic purposes, it may be preferable to install Surround External panels with joints that are sealant filled. In this case, horizontal backing strips are used and joints are sealed to minimise moisture getting into the cavity. Sealant is also applied to the underside of slabs.

Cemintel Surround panels are to be drilled and then fixed onto supporting metal top hats using screws or Surround rivets.

SYSTEM OVERVIEW



Applications

Cemintel Surround is suitable for all building classes where metal top hats can be fixed to framing however, site environmental factors such as wind and corrosivity zones must be taken into account to determine its suitability for a particular application.

The panels and system have been designed to withstand ultimate wind pressures up to 7.0 kPa including cyclonic conditions.



Benefits of Cemintel's Surround External Panels on the ExpressWall Fixing System

- Low maintenance
- No requirement for additional painting costs
- Potential to speed up the construction process
- Large format, lightweight panels are designed to be fixed to top hats which can be fixed to industry standard steel, timber or masonry structural frames
- Cemintel's express jointed fixing system is widely recognised for its high performance
- ExpressWall top hat has a wider fixing surface for increased installation tolerance, allowing panel movement with changes in wind pressures, thermal movement etc.
- Cemintel's pressure equalised ventilated cavity system allows for higher wind loads, minimises water ingress and allows air flow and drainage
- Suitable for Bushfire Attack Level 29 when AS 3959 is followed.
- The unique Surround coloured rivet with pre-assembled rubber sleeve allows slight movement across the panel thereby reducing the stresses created where panels are installed with "fixed" points
- Panels are easy to cut for openings eg. around windows and power boxes
- Termite resistant
- Durable and weather resistant
 - Provides effective protection against wind, rain and temperature extremes, mould and mildew
 - Panels will not rot, swell or warp when correctly installed and maintained
- Fire Resistance – fibre cement sheets can be used where non-combustible material is required under the BCA provisions
- Systems are available for thermal, acoustic and fire requirements as part of an overall solution

System Solutions

Fire Resistance Level (FRL)	Up to 120/120/120, -/180/180 when used in a system with Gyprock fire grade plasterboard	Refer to System Engineering section or the "The Red Book"™
Bushfire Construction	BAL 29 (Construction for Bushfire Attack Level 29 for an external wall)	AS 3959 – 8
Weatherproofing	Suitable for a serviceability wind pressure of +2.50 kPa when installed as a pressure equalised system.	AS 4284
Wind actions (including Cyclonic)	Suitable for ultimate wind loads up to 7.0 kPa with Cemintel Rigid Air Barrier, including cyclonic conditions, and up to 2.5 kPa with Enviroseal ProctorWrap CW-IT	AS 4040.3

A technical Data Sheet can be downloaded from cemintel.com.au

A large, stylized graphic of the number '04' in white, with a dark blue shadow effect, set against a dark blue background. The '0' is a simple circle, and the '4' is composed of geometric shapes.

DESIGN + AESTHETIC
CONSIDERATIONS

DESIGN + AESTHETIC CONSIDERATIONS



This section outlines some important areas for consideration in determining whether Cemintel Surround External is suitable for the required application. The following points are not exhaustive. It is the responsibility of the Architect / Building Designer to ensure the design conforms to BCA requirements and other relevant building standards that may exist for that location. This guide should be read in conjunction with the BCA.

Panels, top hats and structural framing are required to resist wind loads that are specific to the building site. Additional “local pressure factors” apply to the panels and top hats in accordance with the wind code AS 1170.2.

Once wind loads have been determined top hat spans, fastener spacings, and sheet fixing details can be selected from the appropriate tables in the ‘System Engineering’ Section of this guide. It is also the responsibility of the Architect/Building Designer to select the appropriate corrosivity category.

Panel Finish

All Surround panels are colour bodied (also known as colour through). This works to enhance and give added depth to the surface colour of the panel. It also means that any chips or damage to the panels are less evident.

Base, String and Leather

Surround’s Base, String and Leather finishes have an opaque coating applied to the surface and colour variation between panels is minimal. This allows for mixing and matching from a design perspective.

Note: String and Leather have a three dimensional surface texture. They should be laid in the same direction (ie either horizontal or vertical) rather than in mixed directions.

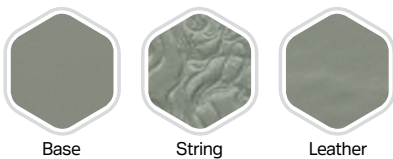

Base

String

Leather

Metal

Metal displays a subtle metallic sheen when light reflects off the surface from different viewpoints. Like Marl, there is a visible difference between production runs so this product is batched.



Metal

Because of variations between batches, particular attention needs to be taken to order extra stock of Marl or Metal products. Allow enough for cuts and extra sheets should be set aside in case panels have to be replaced in the future.

Marl

Marl has a more transparent coating which showcases the inherent cement and fibre nature of the underlying product. There is a visible difference between production runs so this product is batched.



Marl

Panel Layout

Panel layout should take into account the following:

- Aesthetic design
- Top hat spacing to allow for expressed joint widths (Refer Fig. 4.01)
- 8-10mm recommended joint width
- Type of structural support
- Size and location of openings
- Building size
- Location of building control joints

Panel layout can be in a grid pattern where vertical and horizontal joints are continuous (Refer Fig. 4.02 & 4.03). In these layouts, construction joints may be positioned behind any vertical or horizontal sheet joint (refer to “Construction Drawings & Details” section).

Panel layout can also be in a vertical or horizontal half-bond pattern where some joints are discontinuous (Refer Fig. 4.04 & 4.05).

This is not an exhaustive list of panel layouts.

FIGURE 4.01 Typical Top Hat set-out - 1200mm Width Vertical Panels with 10mm Joints shown

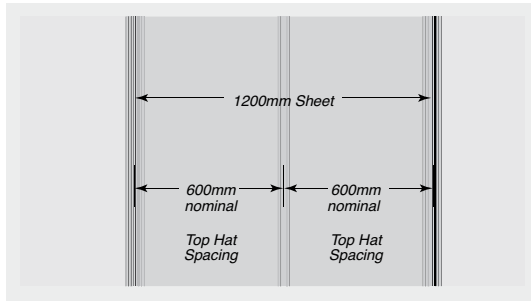

FIGURE 4.02 Horizontal Sheeting Aligned Grid Pattern

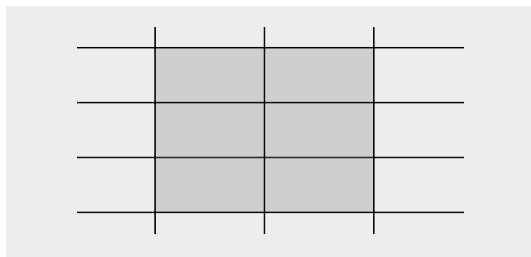

FIGURE 4.03 Vertical Sheeting Aligned Grid Pattern

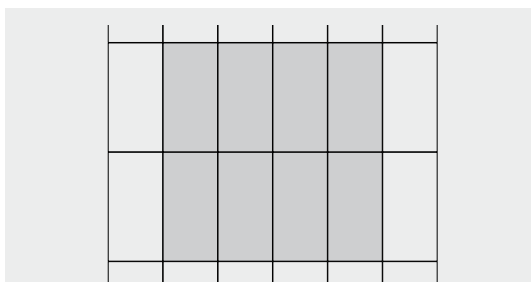

FIGURE 4.04 Horizontal Sheeting Half-bond Pattern

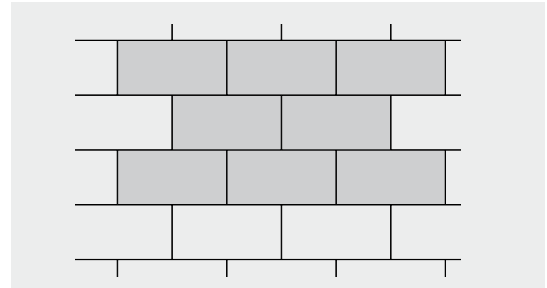

FIGURE 4.05 Vertical Sheeting Half-bond Pattern

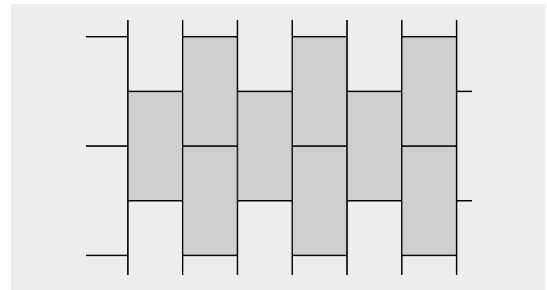
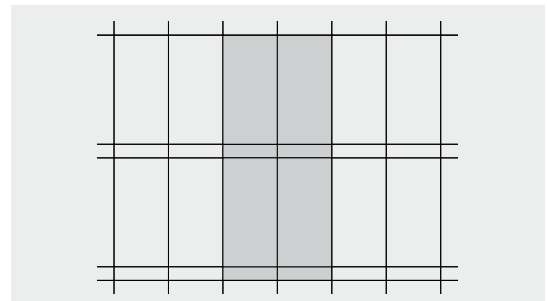

FIGURE 4.06 Skirt Panel (Floor to Floor in Excess of 3m)



Structural

Framing and Substrate Options

Surround External panels and ExpressWall system can be fixed to either timber or steel framing, as well as to masonry and concrete substrates.

For timber and steel framing, the minimum requirement shall be in accordance with the following standards:

- AS 1720 – Timber Structures.
- AS 1684 – Residential Timber-Framed Construction.
- AS/NZS 4600 – Cold-Formed Steel Structures.
- AS 3623 – Domestic Metal Framing.

DESIGN + AESTHETIC CONSIDERATIONS



Timber Stud or Steel Framing

Cemintel ExpressWall Top Hats and Intermediate Top Hats must be installed vertically onto horizontal H515 top hats and supported by a primary structural system (ie timber or steel stud framing – Refer Fig. 4.07).

FIGURE 4.07 Fixing to Timber or Steel Stud Framing

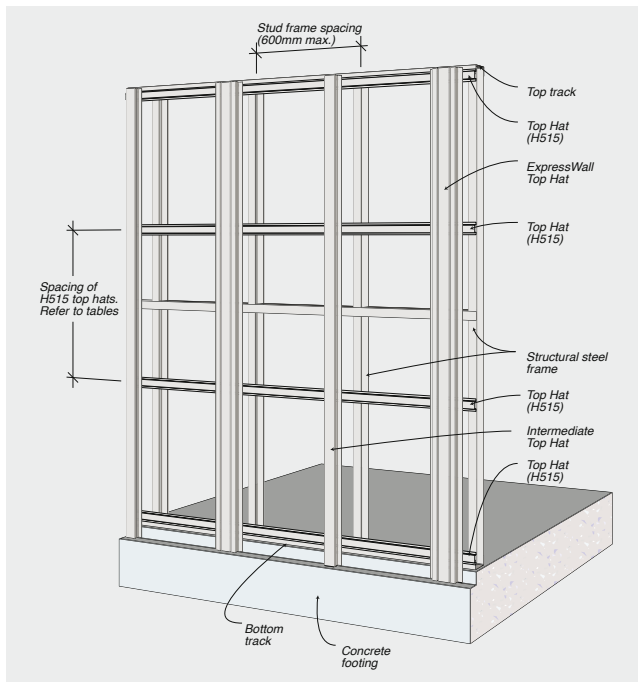

Alternatively ExpressWall framing can be fixed to appropriately designed steel or timber framing. The frame must be designed to support the top hats at the top and bottom of the wall and at cross members within the span of the wall (Refer Fig 4.08).

The connection of Top Hats to the structural frame requires engineering design. It is the responsibility of the project engineer to specify the connection of the top hats to the support structure.

Masonry or Concrete Walls

ExpressWall framing can also be fixed over masonry or concrete walls (Refer Fig. 4.10). All top hat connections must be designed by the project engineer.

Wind Pressures

Surround External installation has been evaluated for use in all Australian wind zones up to and including N6 and Cyclonic C4 in accordance with AS 4055 for wind pressures up to 7.0 kPa under AS 1170.2 including cyclonic zones when fixed to steel framing. Fibre cement is not resistant to the projectile penetration specified in AS 1170.2.

In highly corrosive environments, appropriate measures should be taken to protect the frame and metal components from corrosion. Refer to Corrosive Zones table in 'System Engineering' section.

It is critical that the frame is true and plumb. Industry best practice for framed tolerance is 5mm misalignment over 3000mm. Retrofitting Surround External to pre-existing walls must be assessed with the squareness of the substrate.

AS/NZS 1170.0 Table C1 suggests that support framing be designed for a maximum deflection of span/250. Span tables are located in 'System Engineering' section.

FIGURE 4.08 Fixing to Steel or Timber Framing

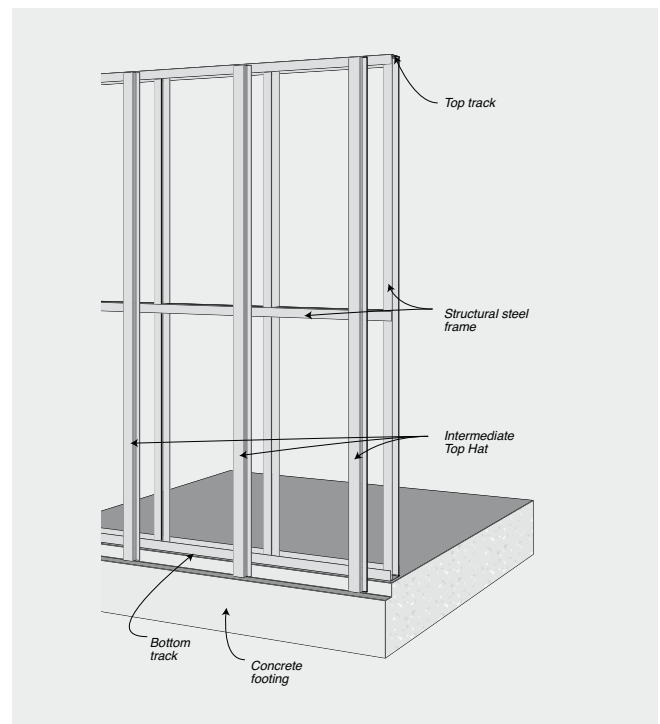

DESIGN + AESTHETIC CONSIDERATIONS

FIGURE 4.09 Fixing to Masonry Wall

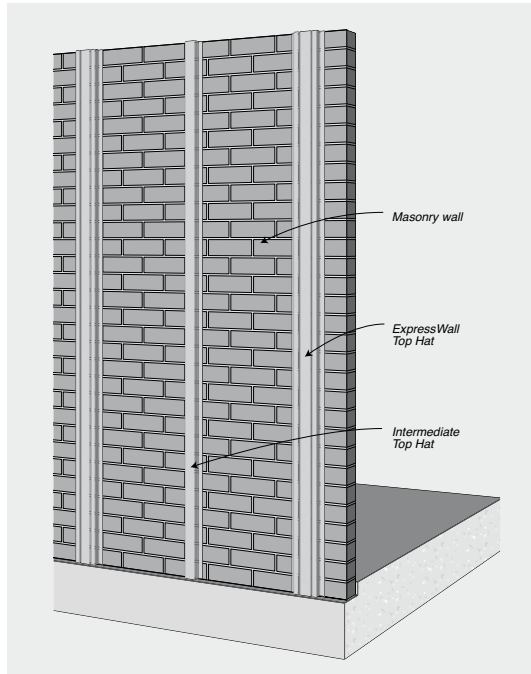

Intermediate Top Hat is used to support the panels at intermediate locations in between ExpressWall top hats. The Intermediate top hat is a rolled steel section which is manufactured from galvanised steel (Z275) of 1.15mm BMT.

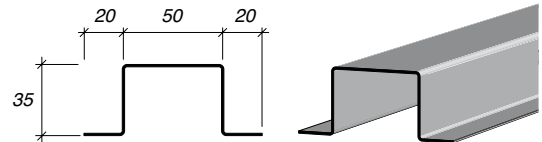

H515 Top Hat is installed horizontally to the face of steel or timber stud framing to support the ExpressWall Top Hats and Intermediate Top Hats. Top Hat H515 is a Rondo rolled steel section which is manufactured from galvanised steel (Z275) of 1.15mm BMT.

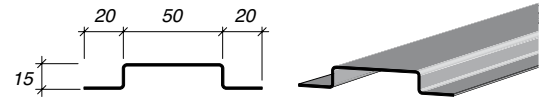

Top Hats

Cemintel's ExpressWall Top Hat is a purpose designed rolled steel section for supporting the vertical edges of the panels. The unique profile acts to accommodate movement of the sheets at the vertical joints. It is designed to be used in conjunction with the ExpressWall Vertical Gasket for added weather resistance. The ExpressWall Top Hat is manufactured from galvanised steel (Z275) and is the subject of Patent No 2004240142. It is available in 1.15 BMT or 0.75 BMT.

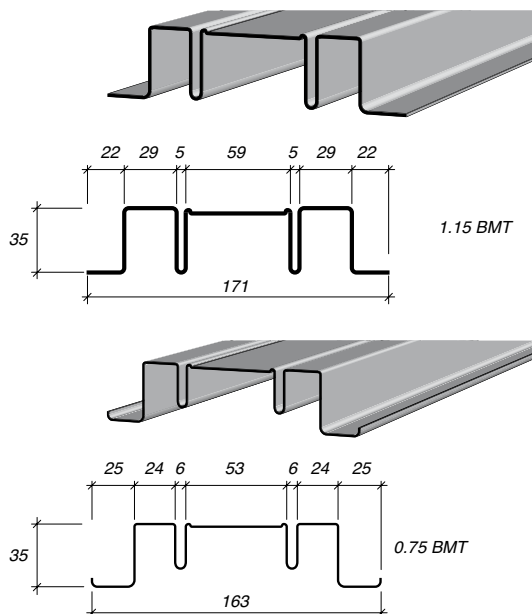

Pre-Drilling Panel Holes

Holes for rivets must be pre-drilled. This activity can be done off-site prior to installation. For **Surround rivets**, a 9.5mm carbide tipped drill bit with centering tip must be used to accommodate the Surround rivet. Do not use hammer action when drilling.

Clean dust out of holes.

Face Fixings

Panels are fixed to top hats using Surround Rivets. Specific Gesipa Accubird rivet gun accessories must be used to ensure correct fixing of the Surround Rivet. Rivets are manufactured from stainless steel consisting of V4A stainless steel (equivalent to 316 grade) mandrels and V2A stainless steel (equivalent to 304 grade) sleeves.

Surround rivets are available in colour matching finish.

The Surround rivet, with its unique rubber sleeve, allows a very slight movement across the whole panel thereby reducing the stresses created where panels are installed with "fixed" points. Note: Use of standard rivets and gun heads is NOT ACCEPTABLE.

DESIGN + AESTHETIC CONSIDERATIONS



Window & Door Openings

Cemintel Surround is compatible with industry standard aluminium windows. Aluminium windows MUST NOT have sill drain holes that can direct water into the wall cavity.

With the cavity created by the top hat system, particular attention needs to be given to the set out of windows and doors.

The depth of the window needs to be taken into account in the design of the building frame so that the front face of the panel is properly aligned with the window and that the flashing is installed correctly.

If using a rigid air barrier or other sheeting, the thickness of this also needs to be accounted for to achieve a flush finish when determining window set out and reveal depths.

Cemintel recommends installing a sub frame with all windows. Refer to typical window detail drawing in 'Construction Drawings and Details' section of this guide.

Eaves Junction

Air is circulated to the wall cavity. It is not recommended that air be vented into the roof space.

Control Joints

Movement Control Joints

Control joints provided in the panel layout should be aligned with movement control joints provided in the framing.

When undertaking building additions, a movement control joint must be installed at the junction of the existing framing and the new framing. Cladding systems must be discontinuous at this joint (refer to the "Construction Drawings & Details" section).

When setting out panels, design consideration should be given to the location of joints to ensure that minimum panel lengths are observed.

Horizontal Control Joints

A horizontal control joint is required beneath every floor junction to accommodate any expected deflection. The magnitude of the deflection must be verified by the project engineer (refer to the "Construction Details" section).

Vertical Control Joints

Vertical control joints to allow for differential movement are required at the supports of fascia trusses and at the junction of structural elements of different stiffness, such as between concrete columns and stud frames (refer to the "Construction Drawings & Details" section).

A control joint must also be installed when a masonry wall adjoins framed construction, and at the junction of framed additions or existing buildings, to allow for differential movement. Refer to 'Construction Drawings & Details' section.

Vertical joints in panels must be aligned and extend for the full height of continuous panelling, although additional joints may be placed over openings for ease of installation. As the joints are expressed, consideration to the positioning of joints is important for aesthetic reasons. Placing joints at sides or above openings, or the use of full height windows can reduce the visual impact of joints.

ExpressWall top hats in both 1.15BMT and 0.75BMT steel have been designed to elastically deform when pressure is applied during panel fixing. They have a recessed area to accept a vertical gasket tape which is made from closed cell foam with good weathering and UV resistance. It has a low compression set and low water permeability.

Structural Bracing

Cemintel Surround panels are indirectly attached to the structural framing by way of metal top hats. As a consequence, they are not designed to provide wall bracing.

If required, bracing must be provided in the structural framing with methods such as sheet or strap bracing. Where sheet bracing is used, the entire wall framing to be clad with Surround panels must be sheeted to maintain a uniform fixing plane.

Note: window setout will be affected.

Termite Management

There is a wide variety of methods for managing termite entry to buildings, and selecting the appropriate method for any structure depends on specific risk factors and the form of construction.

Refer to your local pest management service, the BCA, AS 3660: Termite Management, and your local building authorities for more information about the requirements for the design of a suitable termite management system.



DESIGN + AESTHETIC CONSIDERATIONS

Moisture Management

To ensure occupant health, safety and comfort and to protect the building frame from damage, a moisture strategy with the following objectives is required:

- Prevent external moisture entering the building; and
- Prevent the accumulation of internal moisture in a building.

Weatherproofing

Properly designed rigid air barriers including, fibre cement, masonry, concrete, timber and metal sheeting may be utilised as an air barrier. Alternatively, various properly designed wall wraps may be utilised. The maximum serviceability wind pressure may be governed by the type of air seal/barrier selected.

The Surround system has been tested and assessed to AS 4284 to withstand water ingress for serviceability wind loads of up to 2.5 kPa for the cavity system using Cemintel Rigid Air Barrier.

Select wall wraps can provide a water resistant and air tight barrier when installed appropriately. Wraps have been assessed as suitable as an air barrier for serviceability pressures up to 1.2 kPa. It is recommended that wall wraps used as an air barrier have an air resistance greater than 0.1 MN/m³ when tested to ISO 5636-5. Wall wraps in Table 4.03 meet this requirement. Refer to the Installation section in this manual and “Cemintel Design and Installation Guide for Air Barriers” for details on wall wraps and Cemintel Rigid Air Barrier.

Windows must be a front draining style and have appropriate flashing to prevent moisture ingress and penetrations should be effectively sealed at the air barrier and at the cladding.

Condensation

Condensation occurs as air cools and contacts cold surfaces that are below the air's dew point. Absorptive materials such as brick, cement sheet and timber are permeable and act as a buffering material until they become saturated, whilst non-absorptive materials such as steel and glass reach saturation quickly. Water can then accumulate and must be allowed to dry or drain away. Moist surfaces can result in health issues for occupants and lead to degradation of building materials and loss of structural integrity.

The likelihood and severity of condensation is largely a function of:

- Climate (primarily temperature and humidity including seasonal and diurnal variations)
- Occupancy and building use
- Material properties of the building envelope (including insulation material type and R-Value)

- Passive and mechanical ventilation
- Air tightness
- The building envelope's ability to allow or prevent the movement of vapour.
- The building envelope's ability to act as a water barrier behind the primary cladding element.

CSR recommends that architects/designers undertake a condensation risk analysis prior to selecting vapour control membranes. A rigid air barrier may be required where buildings are subject to higher wind loads, and in some climate zones may require the incorporation of a vapour barrier membrane in addition to the rigid air barrier. Greater use of insulation, better sealing to restrict air movement, and increased use of air conditioning leads to larger differences between the temperature and water vapour content of indoor environments and adjacent outdoor areas and greatly increases the risk of condensation at surfaces and interstitial spaces.

The Australian Building and Construction Board (ABCB) “Condensation in Buildings Handbook 2014” provides guidance on managing condensation. This guidance includes review of Bureau of Meteorology climate statistics (including maximum and minimum average monthly temperatures together with average monthly dew point temperatures). This highlights the likelihood of condensation which occurs when minimum temperature falls below the dew point, and identifies the daytime drying potential.

Wall Wraps/Rigid Air Barriers

The fabric of the building separates the interior and exterior environments and is subject to the movement of heat, air, water, and water vapour. Multiple materials are usually required to form effective control layers in the interstitial spaces between the exterior cladding and internal lining of a building.

The appropriate membrane (ie. wall wrap or sarking) for an application will depend on the local climate, building type, service wind pressure, use and orientation, material R-Value of the insulation, as well as the degree and location of ventilation.

Vapour barriers restrict the transmission of water vapour, while vapour permeable membranes allow the transmission of water vapour.

The wall wrap must have a ‘water barrier’ classification to AS/NZ 4201.4. A non-water barrier classification is not suitable. Wraps included in this manual, and Cemintel Rigid Air Barrier, have achieved the classification water barrier. Wall wraps must meet the requirements of AS/NZS 4200.1: Pliable building membranes and underlays – Materials.

CSR provides several product options for use as air barriers and moisture barriers.

DESIGN + AESTHETIC CONSIDERATIONS

**TABLE 4.01** Recommended Products for Moisture Management of Walls

Climate (BCA Zone)	Guidance on Vapour Control	Performance and Category	Recommended CSR Products. (Refer to Table 4.03)
Warm-Humid, or Tropical climates (Zone 1)	Where vapour flow is typically inward, such as where the building is air-conditioned for cooling, the membrane should function as a vapour barrier.	Vapour Barrier - Class 1 or 2	<ul style="list-style-type: none"> Bradford Thermosteal membranes Bradford Thermosteal Firespec Cemintel Rigid Air Barrier with a Vapour Barrier Membrane
Temperate or Hot-Dry (inland) climates (Zones 2, 3, 4, 5)	These climates have varying diurnal and seasonal temperature changes that can affect the direction of the water vapour flow. In most cases a vapour permeable membrane outside the insulation is recommended to avoid creating a moisture trap, allowing drying in either direction. Where a high level of thermal insulation is used, a high degree of permeability may be required, and in some locations a vapour barrier is required. Expert guidance based on local experience should be sought.	Vapour Permeable or Vapour Barrier Class 2, 3 or 4 as required	<ul style="list-style-type: none"> Bradford Enviroseal membranes Bradford Thermosteal membranes Bradford Thermosteal Firespec Cemintel Rigid Air Barrier Cemintel Rigid Air Barrier with a Vapour Barrier Membrane
Cold climates (Zones 6, 7, 8)	Where there is a strong tendency for outward migration of vapour and a high risk of condensation, vapour permeable membranes should be installed on the cold, external side of the insulation. ⁽¹⁾	Vapour Permeable Class 3 or 4	<ul style="list-style-type: none"> Bradford Enviroseal membranes. Cemintel Rigid Air Barrier

(1) The use of a Class 3 membrane such as Cemintel Rigid Air Barrier may not be sufficient in some cold climates. If a Class 4 membrane cannot be used, a solution may include the use of a material to the interior side of the insulation that acts as a vapour barrier, e.g. a Class 1 or 2 membrane or a vapour sealed plasterboard lining coupled with a mechanical ventilation solution. Seek expert advice prior specifying systems for these regions.

TABLE 4.02 Recommended CSR Products for Moisture Management of Walls

Product	Vapour Permeance Class AS/NZS 4200.1	Vapour Permeance ASTM E96 µg/N.s	Weather exposure limit prior to cladding
Thermosteal 733	Class 1	<=0.0022	1 month
Thermosteal Resiwrap	Class 1	<=0.0022	1 month
Thermosteal Wall Wrap/XP	Class 1	<=0.0022	1 month
Thermosteal Firespec	Class 2	0.0022 to 0.1429	1 month
Thermosteal Wall Wrap Prime	Class 2	0.0022 to 0.1429	1 month
Cemintel Rigid Air Barrier	Class 3	0.25	6 months (panel) 2 months (tape)
Enviroseal ProctorWrap CW, Enviroseal ProctorWrap CW-IT	Class 4	4.2	2 months
Enviroseal ProctorWrap HTS	Class 4	4.0	2 months
Enviroseal ProctorWrap RW	Class 4	4.5	1 month

Insulation and Energy Efficiency

Energy efficiency requirements for buildings are set out in the BCA as performance requirements and acceptable construction practices, and are dependent on geographical climate zones. To meet the requirements, it is recommended that insulation be installed in the wall framing. Check with local building authorities for minimum insulation requirements.

The level of insulation provided in a wall is described by its R-value. The higher the R-value the greater the insulation provided. R-values for some systems are given in the Thermal Performance Selection Table. (Refer Table 4.03)



DESIGN + AESTHETIC CONSIDERATIONS

Refer to Components for product information. Insulation also improves the acoustic performance of the wall against outside noise.

Clause J0.5 of the NCC requires a thermal break to be provided for in some situations. The associated explanatory note states that a thermal break is needed when a metal framing member directly connects the external cladding to the internal lining. For the ExpressWall system, the cladding is indirectly fixed to

the framing with a secondary member (top hat), and no thermal break is required for this wall system.

Solar Reflectance/Absorptance

Cemintel Surround has been tested to ASTM E 903-96 'Standard Test Method for Solar Absorptance, Reflectance and Transmittance of Materials Using Integrating Spheres'.

Values are included in the Technical Data Sheet.

TABLE 4.03 Thermal, Fire & Acoustic Performance Tables

The wall system contributes towards the total wall U or R value, which is to be determined in accordance with the BCA Vol 1 J1.5 or Vol 2 3.12.1.4 as appropriate. The values presented may be used for comparative purposes. They are calculated through the wall with no thermal bridging path and assume:

- 1 layer Surround External panel fixed to ExpressWall top hat framing system
- Horizontal H515 Top Hats
- Insulation and Wall Wrap/Sarking as per system table
- Steel Studs (90mm min.) at 600mm maximum centres
- 1 layer x 10mm Gyprock® standard plasterboard fixed to the inside of framing

Insulation	Wall Wrap/Sarking	Winter Total Wall R-Value	Summer Total Wall R-Value
Nil	Bradford Thermoseal Wall Wrap	1.1	1.0
Nil	Bradford Thermofoil 733*	1.8	1.6
Bradford 75mm Gold Batts R1.5	Bradford Thermoseal Wall Wrap	2.1	1.9
Bradford 75mm Gold Wall Batts R2.0	Bradford Thermoseal Wall Wrap or Enviroseal ProctorWrap RW, CW/CW-IT or HTR	2.6	2.3
Bradford 75mm Gold Wall Batts R2.0	Bradford Thermoseal Wall Wrap Prime	2.6	2.3
Bradford 90mm Gold Wall Batts R2.5	Bradford Thermoseal Wall Wrap or Enviroseal Proctorwrap RW, CW/CW-IT or HTR	3.1	2.8
Bradford 90mm Gold Wall Batts R2.7HP	Bradford Enviroseal Proctorwrap RW, CW/CW-IT or HTR	3.3	3.0
Bradford 90mm Gold Wall Batts R2.7HP	Bradford Thermoseal Wall Wrap or Resiwrap	3.3	3.0

Notes:

* Bright side of foil facing stud cavity. Bradford Thermofoil 733 is wall wrap/sarking with reflective finish both sides. Using an alternative product with anti-glare finish will REDUCE the stated R-value performance.

- Values calculated in accordance with AS 4859.1, and are based on an unventilated cavity and using Bradford Thermal Calculator v1.2. (not publicly available).
- All Bradford wall wrap/sarking products detailed above have a Flammability Index of ≤ 5 to AS/NZS 1532 Part 2, making them suitable for Bushfire and Fire Rated wall systems.
- FRL/Thermal/Acoustic Systems information courtesy of Gyprock The Red Book.

Wall Wrap/Sarking Air Barrier or Rigid Air Barrier

Wall Wrap/Sarking is suitable for the following wind load situations:

TABLE 4.04

Description	Maximum Wind Loading (Ultimate) (kPa)
Bradford Enviroseal ProctorWrap CW-IT	2.5
Cemintel Rigid Air Barrier	7.0

Cemintel Rigid Air Barrier to be installed in the following wind load situations

Cemintel Rigid Air Barrier sheet to be installed in the vertical direction

TABLE 4.05

Stud Centres (mm)	Maximum Wind Loading (Ultimate) (kPa)
600	1.61
450	2.86
400	3.62
300	6.0

Cemintel Rigid Air Barrier sheet to be installed in the horizontal direction

TABLE 4.06

Stud Centres (mm)	Maximum Wind Loading (Ultimate) (kPa)
600	1.97
450	3.51
400	4.94
300	7.0

Note: For specific installation information on Wall Wrap and Rigid Air Barrier, refer to the 'Cemintel Air Barrier Design and Installation Guide'.

DESIGN + AESTHETIC CONSIDERATIONS



Climate Zones for Thermal Design

The following map and tables show the performance levels required for walls (and floors) under the NCC and BCA.

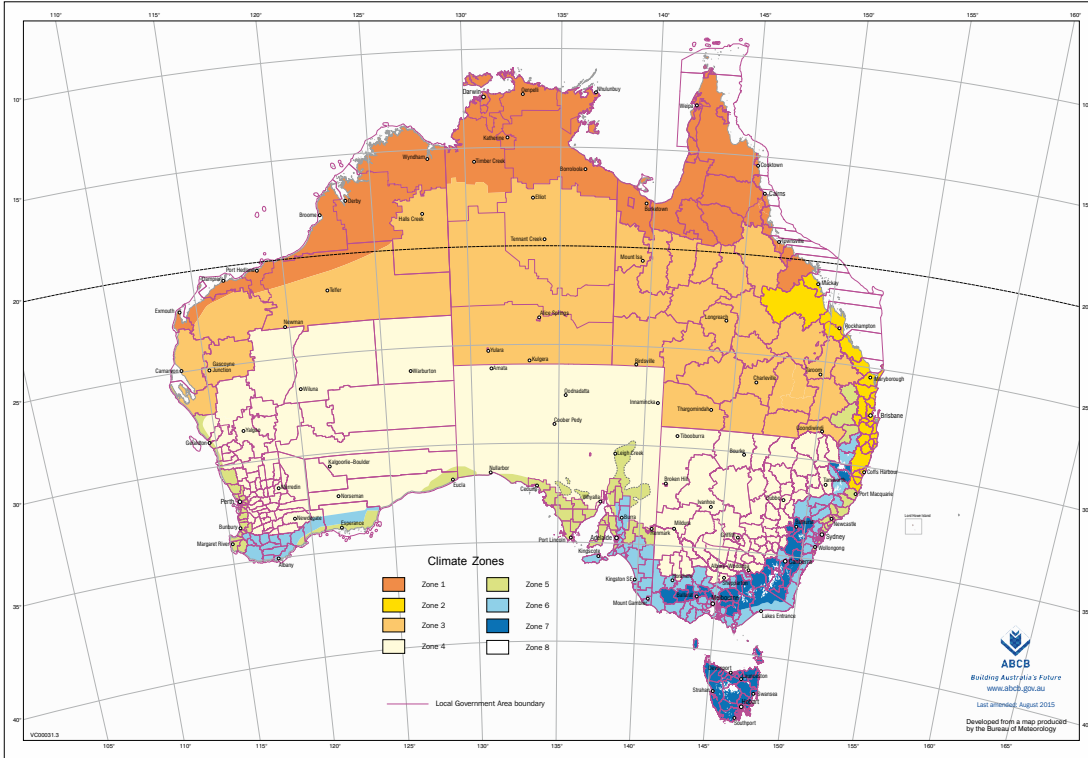

- Step 1:** Determine which climate zone your project is located in Australia from the map above.
- Step 2:** From Table 4.07, determine the design conditions ('Summer' heat flow in or 'Winter' heat flow out) according to the building class and climate zone for your project. (Note building classes are defined by the NCC.)
- Step 3:** Refer to the roof, wall or floor system applicable to your construction type to determine Total R-Value (refer to Table 4.03).

Note: Some applications may achieve Total R-Values sufficient to comply with the minimum performance levels of the Deemed-to-Satisfy requirements contained in the Energy Efficiency Provision of the NCC.

TABLE 4.07 Design Conditions ('Summer' heat flow in or 'Winter' heat flow out). Source: ICANZ Handbook.

Climate Zone	1	2	3	4	5	6	7	8
		<300m Altitude	>300m Altitude					
Class 1&10	Summer	Winter						
Class 2-9	Summer						Winter	



DESIGN + AESTHETIC CONSIDERATIONS

Fire Performance

Façade Fire Performance – Class 2 to 9 Buildings

Deemed-to-Satisfy (DtS) Provisions specify that construction for fire resistance must comply with the clauses listed in Section C of the BCA. In particular, Clause C1.9 requires that all components of external walls of buildings of Type A and Type B construction are non-combustible. Cemintel Surround can therefore be used as cladding in these external walls as they are considered to be non-combustible in accordance with C1.9(e), which states that fibre-reinforced cement sheeting may be used wherever a non-combustible material is required.

Fire Rated Wall Construction

Cemintel Surround External can be used as part of a system to achieve a fire rated wall construction. Systems may be selected from the 'System Engineering' section and are also detailed in Gyprock The Red Book.

Extreme Climate Conditions

Bushfire Zones (BAL)

Protection against bushfire attack requires a comprehensive and systematic approach that includes the specification of internal linings, external walls and insulation materials. When installed according to regulations and combined with appropriate insulation materials, Surround panels comply with the requirements of AS 3959 Section 8 'Construction of Bushfire Attack Level 29 (BAL-29) for an external wall. For additional bushfire requirements, refer to the BCA.

For a **Flame Zone (FZ)** application, select a 30/30/30 FRL system (or higher) as advised by the Project Engineer or in accordance with the Gyprock Red Book.

Corrosive Zones

Consideration of corrosivity zones should be taken into account. While Surround panels are not subject to corrosion, consideration needs to be made regarding the impact of climate conditions on system components such as screws, rivets and metal framing.

Corrosivity zones are detailed in AS 4312 and set out in Table 4.08 at the end of this section.

Surround External panels installed with the ExpressWall fixing system is a pressure equalised ventilated cavity system and may be used in environmental zones up to and including C3 – Medium.

Walls must be sufficiently exposed from above so that rain can perform natural wash-down of the wall. Otherwise all walls which are protected by soffits must be washed down twice per year to remove salt and debris build up, particularly around window/door openings.

Note that a white deposit may develop on stainless rivets over time. This can be prevented by regular washdown of the façade and the fastener heads.

The Architect/Building Designer is responsible for assessing the site in accordance with the standard and local conditions.

Surround External panels installed with the ExpressWall fixing system is not suitable for Corrosivity Zone C5 – Very High. This includes the beachfront in regions of rough seas and surf beaches, and inland for several hundred metres, eg. around Newcastle extending over half a kilometre from the coast. It also includes aggressive industrial areas where the environment may be acidic with a pH of less than 5.

DESIGN + AESTHETIC CONSIDERATIONS



Corrosivity Categories

ISO 9223 has suggested five corrosivity zones based on the first year corrosion rate of mild steel. Refer to AS 4312 – 2008 for details regarding Australian Atmospheric Corrosivity Categories.

Some general statements from this document are below.

TABLE 4.08

ISO 9223 Category	Corrosivity	Steel Corrosion rate $\mu\text{m}/\text{y}$	Typical environment
C1	Very low	<1.3	Dry indoors
C2	Low (most areas of Australia at least 50km from the coast or at least 1km from sheltered bays would be in this category)	1.3-25	Arid/urban inland
C3	Medium (from 1km to 10-50km from breaking surf – much of metropolitan Wollongong, Sydney, Newcastle and Gold Coast are in this category)	25-50	Coastal or industrial
C4	High (primarily coastal areas - from several hundred metres to about 1km inland from breaking surf or from the shoreline to around 50m for sheltered bays)	50-80	Sea shore (calm)
C5	Very high (industrial or marine) – common offshore and on the beachfront in regions of rough seas and surf beaches – can extend inland for several hundred metres (in some areas of Newcastle extends around 500m)	80-200	Sea shore (surf)

Cyclonic Zones

Cyclonic testing on the ExpressWall system has been successfully carried out for positive and negative wind pressures of up to 7.0 kPa. In cyclonic areas ExpressWall and Intermediate top hats of 1.15mm BMT must be used and a minimum 14-G hex head screws are required for fixing top hats to steel sub-framing. Wind loads in this guide refer to ultimate limit state design wind pressures.

Temperature Extremes

Surround External is not warranted for use in freezing conditions where the ExpressPanel is in contact with snow drifts or extremely hot conditions (that is above 60°C).

Other Design Considerations

Services

The ExpressWall fixing system will accommodate services that are run through the framing. Any notches or holes formed must be considered in the framing design.

Renovations

When undertaking building renovations, remove all cladding, wall wrap/sarking and insulation from the original wall framing. Ensure the condition of the framing is in accordance with current requirements and is as true and as plumb as possible (within accepted industry tolerances of 5mm misalignment over 3000mm).

Install additional framing, insulation, air barrier and flashing as required.

Limitations

Surround is not warranted for the following applications:

- Panels with non-vertical face (e.g. parapet capping)
- Wet areas such as bathrooms
- Chimney cladding
- Exposure to temperatures greater than 60°C
- Non vented parapet cladding
- Contact with standing snow or ice
- Fixing of tiles or other materials to the face of the panels as the face is prefinished.

The above listing is not intended to be comprehensive. If in doubt, please contact Cemintel.



05

COMPONENTS + ACCESSORIES

COMPONENTS + ACCESSORIES

05

Note: Codes can change from time to time. Refer to the website for the current list of components prior to ordering.

Cemintel Surround Panels and Colour Matched Accessories

Description	Panel Code	Colour Matched Rivet
BLUEISH Base 1200X3000X8mm	162666	162687
BLUEISH Leather 1200X3000X8mm	162671	162687
BLUEISH String 1200X3000X8mm	162676	162687
BLUEISH Marl 1200X3000X8mm	162643	162687
BLUEISH Metal 1200X3000X8mm	162681	162687
BLACKISH Base 1200X3000X8mm	162667	162689
BLACKISH Leather 1200X3000X8mm	162672	162689
BLACKISH String 1200X3000X8mm	162677	162689
BLACKISH Marl 1200X3000X8mm	162662	162689
BLACKISH Metal 1200X3000X8mm	162682	162689
GREENISH Base 1200X3000X8mm	162668	162688
GREENISH Leather 1200X3000X8mm	162673	162688
GREENISH String 1200X3000X8mm	162680	162688
GREENISH Marl 1200X3000X8mm	162663	162688
GREENISH Metal 1200X3000X8mm	162683	162688
GREYISH Base 1200X3000X8mm	162669	162686
GREYISH Leather 1200X3000X8mm	162674	162686
GREYISH String 1200X3000X8mm	162678	162686
GREYISH Marl 1200X3000X8mm	162664	162686
GREYISH Metal 1200X3000X8mm	162684	162686
WHITEISH Base 1200X3000X8mm	162670	162644
WHITEISH Leather 1200X3000X8mm	162675	162644
WHITEISH String 1200X3000X8mm	162679	162644
WHITEISH Marl 1200X3000X8mm	162665	162644
WHITEISH Metal 1200X3000X8mm	162685	162644
SECONDARY PALETTE		
WHITEOUT	167457	167479
AERO	193018	193025
HUSK	167452	167474
BLACKOUT	193015	193022
STRIKE	193019	193026
VOLTA	167471	167483
MAINLAND	167472	167484
QUINTA	193016	193023
METE	167460	167482
HOVER	193017	193024
MAYA	167453	167475
GAUZE	167458	167486
GARB	167456	167478
GREENBACK	167455	167477
TRUSS GREY	167459	167481
WOODLOT	193014	193021





*Lengths up to 3050mm are available as special orders.

05

COMPONENTS + ACCESSORIES

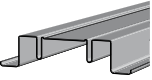
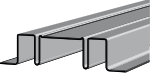
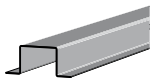
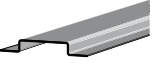
Note: Codes can change from time to time. Refer to the website for the current list of components prior to ordering.

Accessories

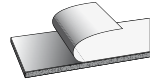
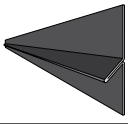
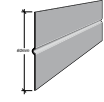



Accessories	Description	Size / Colour	Quantity	Product Code	
TOP HATS					
	ExpressWall Top Hat – is a purpose designed rolled steel section for supporting the vertical edges of the panels. The unique profile also acts to accommodate movement of the panels at the vertical joints. It is designed to be used in conjunction with the ExpressWall vertical gasket. Screws must be carefully installed in 0.75 BMT ExpressWall top hats to avoid thread stripping.	ExpressWall Top Hat 0.75BMT – mass = 1.97kg/m	6000mm	1 each	84746
		ExpressWall Top Hat 1.15BMT – mass = 3.25kg/m (suitable for cyclonic zones – use with exposed head screws).	6000mm	1 each	39124
	Intermediate Top Hat – is used to support the panels at locations other than vertical joints. Intermediate top hat is a Rondo rolled steel section which is manufactured from galvanised steel (Z275) of 1.15BMT.	Intermediate Top Hat 1.15BMT – mass = 1.38kg/m	3600mm	1 each	21086
		Intermediate Top Hat 1.15BMT – mass = 1.38kg/m	7200mm	1 each	21083
	H515 Top Hat – is fixed to structural steel framing to support the ExpressWall and Intermediate Top Hats. Top Hat H515 is a Rondo rolled steel section which is manufactured from galvanised (Z275) steel of 1.15mm BMT.	Top Hat H515 15x50x15mm 1.15BMT – mass = 0.91kg/m	3600mm	1 each	12884
		Top Hat H515 15x50x15mm 1.15BMT – mass = 0.91kg/m	7200mm	1 each	100896
FASTENERS					
	Surround Rivet – for fixing Surround panels to Top Hat framing. Each rivet comes with an already assembled EPDM (TPS-SEBS) gasket. Rivet heads are colour matched to the panel. Rivets are manufactured from stainless steel consisting of V4A (equivalent to 316 grade) stainless steel mandrels and V2A (equivalent to 304 grade) stainless steel sleeves. Note: Use only the Cemintel Rivet and Rivet Gun Head. Standard rivets and gun heads are NOT ACCEPTABLE.	Blueish Blackish Greenish Greyish Whiteish	100 per pack	162687 162689 162688 162686 162644	
		4x18mm			
	Hex Head Screws – for fixing vertical ExpressWall Top Hats and Intermediate Top Hats to H515 or steel framing of minimum 1.15mm BMT in non-cyclonic areas. Hex head self drilling screw 12G-14x20mm, Class 3.	12G-14 x 20mm	1000 per pack	84882	
	Hex Head Screws – for fixing horizontal H515 Top Hats to steel framing minimum 0.75mm BMT and for fixing ExpressWall Top Hats and Intermediate Top Hats to H515 or other steel framing of minimum 1.15mm BMT in cyclonic areas. Hex head self drilling screw 14G, Class 3.		Supplied by others		
	Hex Head Screws Type 17 – for fixing H515 top hats to timber framing in non-cyclonic areas. Hex head self drilling type 17 screw 12Gx25mm, Class 3.		Supplied by others		
Accessories	Description	Size / Colour	Quantity	Product Code	
GASKETS					
	ExpressWall Vertical Gasket - Gaska 1510 self-adhesive tape is made from EPDM closed cell foam which has high UV resistance. The gasket has adhesive on one side (with a release paper) and is adhered to the ExpressWall Top Hat to prevent moisture entry at vertical points.	3.2mm x 48mm x 23m Black	1 each	133978	
BACKING STRIPS					
	Surround Angled Backing Strip – a rolled aluminium section designed to deflect water and create an attractive expressed joint appearance at horizontal joints. Suitable only where a non-sealed façade system is appropriate.	3040mm	1 each	132681	
	ExpressWall Backing Strip – may be used in lieu of Surround Angled Backing Strip for sealant filled system option.	1194mm	1 each	21089	
		2394mm	1 each	21088	
		2994mm	1 each	21087	
	Bond Breaker Tape – Tesa 7492. Required where horizontal joints are sealed.	3.2mm x 48mm x 25m	1 each	13172	

COMPONENTS + ACCESSORIES

05

Note: Codes can change from time to time. Refer to the website for the current list of components prior to ordering.

OTHER

	Corner Backing Angle – metal angle flashing used in some corners. Manufactured from steel with Galvalume AZ150 corrosion resistant coating.	50mm x 50mm x 3030mm	1 each	111498
	Adhesive – for fixing spacer at head junction. Sikaflex 11FC Grey For use as a backing strip adhesive when installing ExpressWall Backing strips	310mL tube	1 each	39378
	Sealant – is used to seal joints for control joints, junctions etc. Sikaflex Sealant PRO-2HP Grey	310mL tube	1 each	11378
	Backing Rod – for sealant backing – used to enable correct filling of joints with sealant. Also used as an air seal at window openings and construction junctions. The diameter of backing rod must be appropriate for the width of the gap being filled.	10mm diameter x 50m roll	1 each	11177
	Cemintel Edge Sealer – for sealing panel edges after on-site cutting.	200ml 2ltr	1 each 1 each	100166 180928
	Flashing & Capping – flashings are to be designed and installed in accordance with SAA-HB39 1997 and good building practice.	Supplied by others		

CSR RIGID AIR BARRIER/WALL WRAPS

	Cemintel Rigid Air Barrier*	1200mm x 3000mm x 6mm	Pack of 30 sheets	170076
	Thermoseal™ Wall Wrap Classification – Non-permeable Reflective Water Classification – High	1350mm – 30m roll	1 roll	107458
		1350mm – 60m roll	1 roll	10576
	Thermoseal™ Resiwrap Classification – Non-permeable Reflective Water Classification – High	1350mm – 30m roll	1 roll	116531
		1350mm – 60m roll	1 roll	116532
		1500mm – 30m roll	1 roll	120121
	Enviroseal ProctorWrap™ Residential (RW) Classification – Permeable High Water Classification – High	1500mm – 50m roll	1 roll	120923
	Enviroseal ProctorWrap™ Commercial (CW) Classification – Permeable High Water Classification – High	1500mm – 50m roll	1 roll	118593

* Cemintel Rigid Air Barrier can be made to order. Minimum order quantities and lead times apply. Refer to Cemintel for more information.

05

COMPONENTS + ACCESSORIES

Note: Codes can change from time to time. Refer to the website for the current list of components prior to ordering.





Accessories	Description	Size / Colour	Quantity	Product Code
	Enviroseal ProctorWrap™ Commercial (CW-IT)	1500mm – 50m roll	1 roll	153675
	Enviroseal ProctorWrap™ High Tensile Roof (HTS)	1500mm – 50m roll	1 roll	122933
	Thermoseal 733 Classification – Non-permeable Reflective Water Classification – High	1350mm – 60m roll	1 roll	86166
	Enviroseal ProctorWrap Hightack Tape – used to seal wall wrap/sarking at overlap joints, around openings and at flashings. Black, single sided, aggressive adhesive tape with a high initial grab and flexible carrier.	60mm x 25m	1 roll	160950
	Enviroseal ProctorWrap SLS Flexi Tape – used to tape corners of openings	60mm x 5m	1 roll	124872

INSULATION







	Bradford Gold Wall Batts – R1.5 (75mm)	1160mm x 430mm	22 pack	113938
		1160mm x 580mm	22 pack	113939
	Bradford Gold Wall Batts – R2.0 (HP) (75mm)	1160mm x 420mm	12 pack	153643
		1160mm x 570mm	12 pack	153648
	Bradford Gold Wall Batts – R2.5 (90mm)	1160mm x 420mm	8 pack	153646
		1160mm x 570mm	8 pack	153651
	Bradford Gold Wall Batts – R2.7 (90mm)	1160mm x 420mm	5 pack	153647
		1160mm x 570mm	5 pack	153652

TOOLS – When using Surround Rivets the following tools must be used

	Surround Drill Bit Ø 9.5mm – for drilling accurate holes in the Surround panel to accept the Surround rivet. Fits standard 10mm drill chuck.		1 each	132673
	Surround Drill Bit Ø 4.1mm – for use with Rivet Centralising Tool to drill accurate rivet holes into the Top Hats		1 each	132675
	Surround Rivet Centralising Tool – for drilling accurate rivet holes in the top hats. Fits a 10mm drill chuck to ensure that the 4.1mm rivet hole is perfectly centred in the pre-drilled panel.		1 each	132674
	Surround Blind Rivet Gun – Cemintel recommends the use of the GESIPA® Accubird Battery Operated Blind Rivet Gun		1 each	133332
	Surround Rivet Gun Nose Piece – required to achieve the correct rivet fixing and offset. Attaches to the Gesipa Accubird battery operated, blind rivet gun and ensures the correct spacing of the rivet head from the panel face. Also designed to seat the larger rivet head correctly and prevent damage to the coloured rivet head. Note: Standard rivet gun nose piece is NOT ACCEPTABLE		1 each	132676

Other Tools

Product	Description	Size	Quantity	Product Code
	Makita Plunge Saw Kit (1300W) includes 1400mm guide rail and bonus 165mm fibre cement saw blade – excellent for cutting cement based sheets. Must be used with a dust extraction system.	165mm	1	165485
	Makita 165mm Fibre Cement Saw Blade – ideal for use with the Makita Plunge saw and other 165mm circular saws fitted with vacuum extraction systems	165mmx20x4T	1	165486
	Dust Extraction		1	Supplied by others
	Grinder Tool		1	Supplied by others

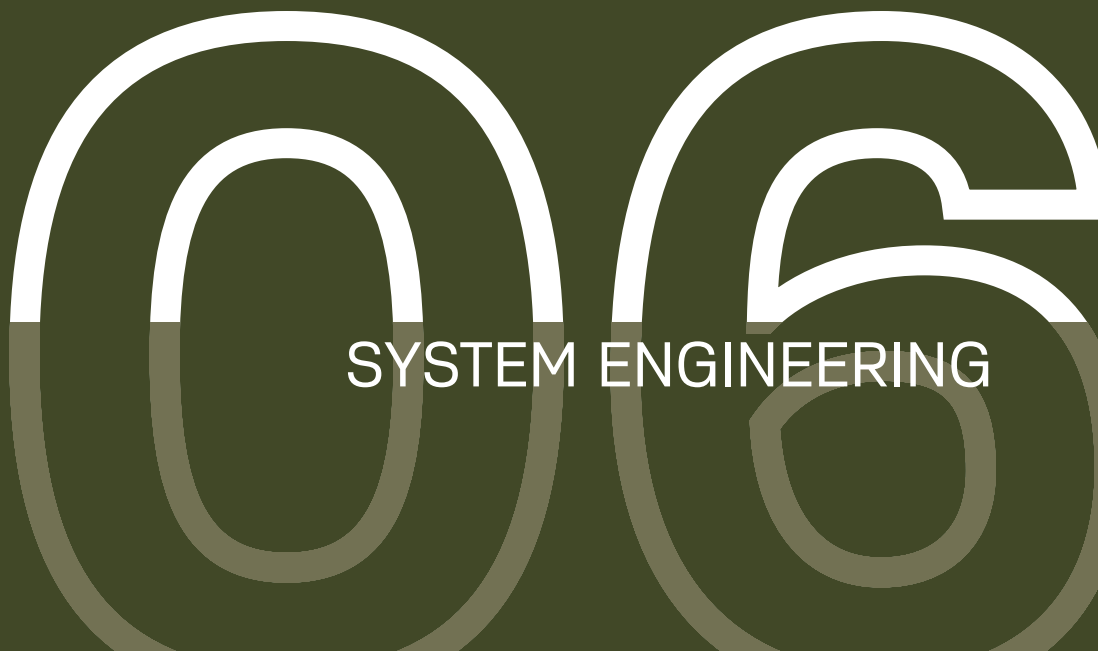

0066

SYSTEM ENGINEERING



SYSTEM ENGINEERING

Design, Detailing And Performance Responsibilities

Surround ExpressWall System

Cemintel engages independent testing laboratories to test and report on the performance of a wall in accordance with the relevant Australian Standards. Consultants with relevant experience will use these test reports to provide opinions and assessments that extend the tested arrangement to include various on-site installation configurations and details that meet appropriate criteria performance.

Project Consultants (Structural, Fire, Acoustic, Etc.)

These consultants are typically responsible for the following:

- Opinions on expected laboratory performance of wall configurations that vary from actual test configuration, such as substitution products and components.
- Judgements about expected field performance using laboratory test reports and practical experience.
- Design, specification and certification of structural, fire, acoustic, durability, weather tightness and any other required performance criteria for individual projects.

This involves the design and selection of building elements, such as wall and floors and their integration into the building considering the following:

- Interface of different building elements and to the structure / substrate.
- Wall and floor junctions.
- Penetrations.
- Flashing issues.
- Room / building geometry.
- Acoustic and water penetration field-testing.

Design Responsibility

Panels, top hats and structural framing are required to resist wind loads that are specific to the building site. Additional 'local pressure factors' can apply to the panels and top hats in accordance with the wind code AS 1170.2. It is recommended that the Architect/ Building Designer assigns the responsibility for the facade design to the Project Engineer. Once wind loads have been determined, top hat spans, fastener spacings, and sheet fixing details may be selected from the appropriate tables in this manual. It is also

the responsibility of the Architect/Building Designer to select the appropriate corrosivity category. Refer to appropriate details in this guide.

The performance levels of walls documented in this guide are either what is reported in a test or the documented opinion of consultants. Performance in projects is typically the responsibility of:

Project Certifier and/or Builder

These professionals are typically responsible for:

- Identifying the performance requirements for the project in accordance with the BCA and clearly communicating this to the relevant parties.
- Applicability of any performance characteristics supplied by Cemintel including test and opinions for the project.
- The project consultants' responsibilities detailed above if one is not engaged in the project.

Cemintel does not provide consulting services. Cemintel only provides information that has been prepared by others and therefore shall not be considered experts in the field.

Any party using the information contained in this guide or supplied by Cemintel in the course of a project must satisfy themselves that it is true, current and appropriate for the application, consequently accepting responsibility for its use.

It is the responsibility of the Architect/Building Designer and engineering parties to ensure that the details in this design guide are appropriate for the intended application.

The recommendations in this guide are formulated along the lines of good building practice, but are not intended to be an exhaustive statement of all relevant data.

Cemintel is not responsible for the performance of constructed walls, including field performance, and does not interpret or make judgements about performance requirements in the BCA in a specific project application.

Note: it is the responsibility of the Project Engineer to specify the connection of the top hats to the support structure. It is also the responsibility of the Project Engineer to calculate the wind loads for the cladding of a project.

SYSTEM ENGINEERING



Stud Wall support framing

ExpressWall top hats and intermediate top hats can be fixed to vertical structurally designed timber MGP10 or higher grade timber, or steel support framing of minimum 0.75mm BMT.

The ExpressWall top hats and intermediate top hats can be supported by horizontally installed H515 top hats fixed at top

and bottom of the wall and at required spacing through the height of the wall. The stud frame walls designed to meet the structural requirements of the project, need to be designed to also support the top hat configurations and Surround cladding.

FIGURE 6.01 ExpressWall Top Hats and Intermediate Top Hats fixed over horizontal H515 Top Hats, fixed to structural stud frames

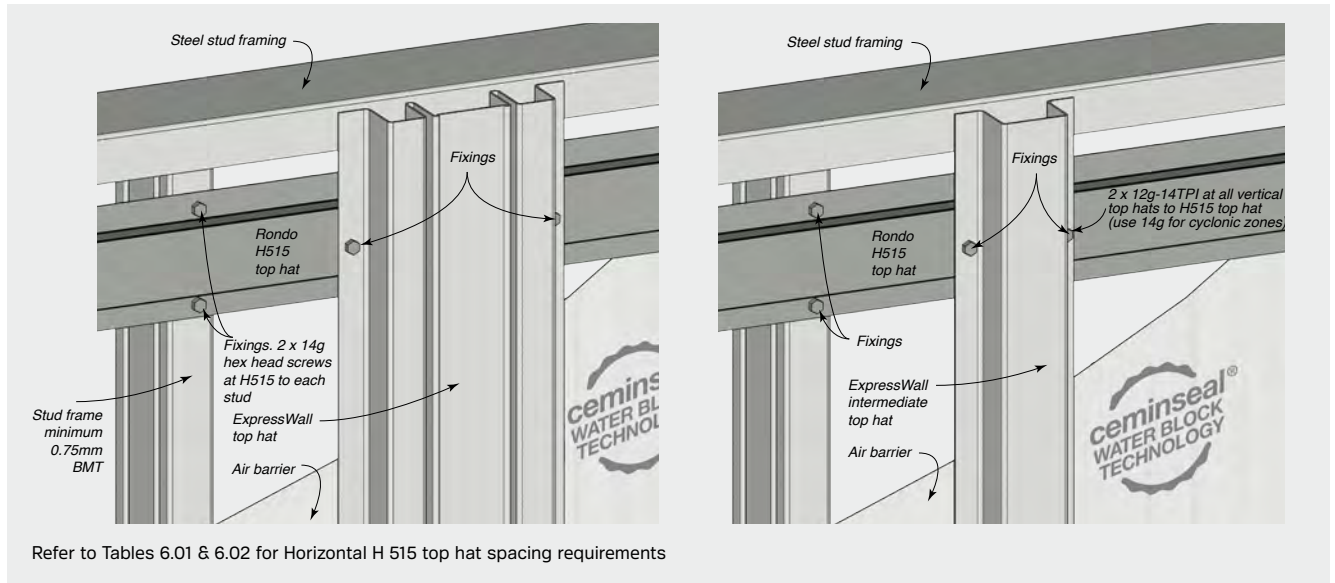

Horizontal Structural Wall Supports

ExpressWall Top Hats and Intermediate Top Hats may be fixed to horizontal structurally designed timber or steel support framing of minimum 1.15mm BMT, without the use of horizontal top hats. It is the responsibility of the project engineer to specify the support structure.

ExpressWall Top Hats and Intermediate Top Hats can be fixed at top plate and bottom plates and at horizontal structural supports positioned at required spacings. Where top plate deflection is required, such as underside of inter-storey junction, the wall framing will need to be appropriately designed to provide additional structural support for the fixing of the vertical top hats.

FIGURE 6.02 ExpressWall Top Hats and Intermediate Top Hats fixed over horizontal structural wall supports

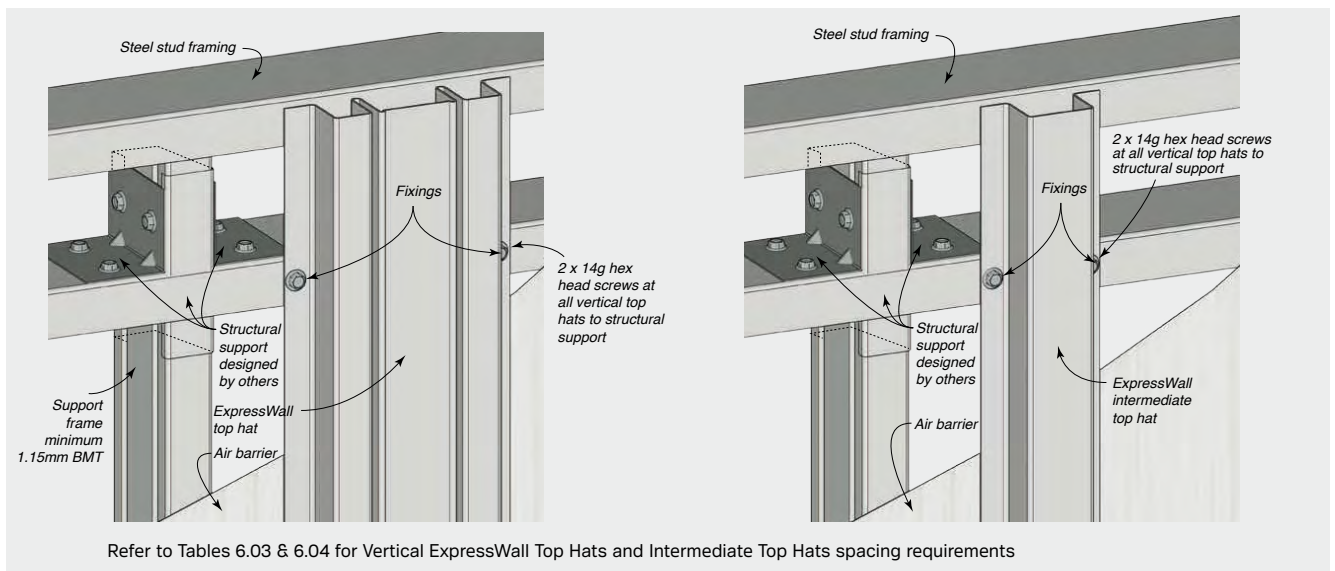



SYSTEM ENGINEERING

Spacing of Horizontal H515 Top Hats

Span Tables / Wind Loads

ExpressWall Top Hats can be fixed to appropriately designed timber or steel stud framing. The frame must be designed to support top hats at the top and bottom of the wall, and at cross members. Installing H515 top hats horizontally over designed framing provides cross members to which the ExpressWall top hats can be fixed to.

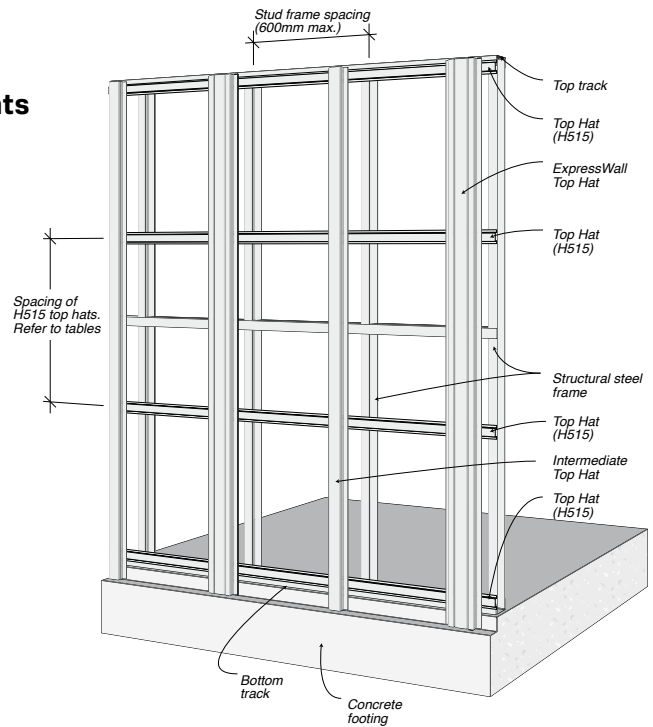

H515 Horizontal Top Hats – RESIDENTIAL – BCA Classes 1 and 10 – General & Corner Zones

TABLE 6.01

Wind Classification (AS4055)	Spacing of H515 Top Hats - Horizontal Top Hats Fixed to Three or More Studs - Timber & Steel Framing			
	Studs 0.75BMT @ 600mm centres maximum		Studs 1.15BMT or Timber Studs @ 600mm centres maximum	
	General Zones	Corner Zones	General Zones	Corner Zones
N1	1473	1473	1769	1769
N2	1473	982	1769	1179
N3/C1	982	737	1179	885
N4/C2	737	491	885	590
N5/C3	589	327	708	393
N6/C4	421	246	505	295

Note: H515 Horizontal Top Hats connection to steel stud frame of minimum 0.75mm BMT use 2 x 14g hex head screws at each stud. For timber wall studs MGP10 or higher grade timber use 2 x 12g-11TPI x 25mm Type 17 hex head screws at each stud.

H515 Horizontal Top Hats – COMMERCIAL – BCA Classes 2-9

TABLE 6.02

Design Wind Pressure (Ultimate) kPa	Spacing of H515 Top Hats - Horizontal Top Hats Fixed to Three or More Studs - Timber & Steel Framing			
	Studs 0.75BMT Stud Spacing (mm)		Studs 1.15BMT or Timber Studs Stud Spacing (mm)	
	450	600	450	600
1.0	1768	1473	1974	1769
1.5	1179	982	1316	1179
2.0	884	737	987	885
2.5	707	589	790	708
3.0	589	491	658	590
3.5	505	421	564	505
4.0	442	368	494	442
4.5	393	327	439	393
5.0	354	295	395	354
5.5	322	268	359	322

Note: H515 Horizontal Top Hats connection to steel stud frame of minimum 0.75mm BMT use 2 x 14g hex head screws at each stud. For timber wall studs MGP10 or higher grade timber use 2 x 12g-11TPI x 25mm Type 17 hex head screws at each stud.

SYSTEM ENGINEERING



ExpressWall and Intermediate Top Hat Spacings

The design capacities of the Cemintel Surround façade system are in limit state format and intended for use with AS/NZS 1170.2.

To obtain equivalent permissible load capacity, divide the “ultimate wind capacity” in Table 6.04 or Table 6.06 by 1.5.

The top hat capacities have been calculated in accordance with AS 4600: Cold Formed Steel Structures and are applicable for 0.75BMT and 1.15BMT ExpressWall top hats and for 1.15BMT

intermediate top hats. The deflection of the top hats as detailed in these tables is no more than span/250 when subjected to serviceability wind load of 68% of ultimate wind loads.

Top hat spacing will vary depending on wind loads and panels may be installed with Single Spans (Refer Fig. 6.03) or Double Spans (Refer Fig. 6.04). Top hat spacing is nominal and may be increased by up to 20mm to accommodate panel joint width.

**ExpressWall and Intermediate Top Hats
RESIDENTIAL – BCA Classes 1 & 10**

TABLE 6.03

Design Wind Pressure (Ultimate) kPa	Maximum Span of Vertical ExpressWall and Intermediate Top Hats			
	Spacing of Vertical Top Hats (mm)			
	General Zones		Corner Zones	
	400	600	400	600
N1	2250	1850	2250	1850
N2	2250	1850	1950	1700
N3/C1	1950	1700	1800	1550
N4/C2	1800	1550	1550	1200
N5/C3	1650	1350	1200	NA
N6/C4	1400	1100	1000	NA

See notes below.

FIGURE 6.03 Single Top Hat Span Installation

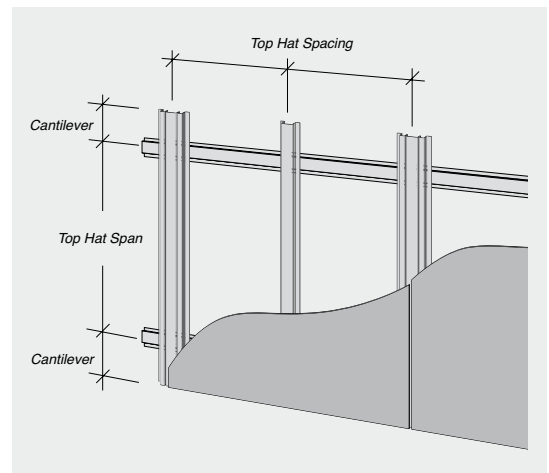

**ExpressWall and Intermediate Top Hats
COMMERCIAL – BCA Classes 2-9**

TABLE 6.04

Design Wind Pressure (Ultimate) kPa	Maximum Span of Vertical ExpressWall and Intermediate Top Hats			
	Spacing of Vertical Top Hats (mm)			
	300	400	450	600
1.0	2450	2250	2150	1950
1.5	2150	1950	1900	1700
2.0	1950	1800	1700	1550
2.5	1800	1650	1600	1350
3.0	1700	1550	1450	1200
3.5	1600	1400	1350	1100
4.0	1550	1300	1200	NA
4.5	1450	1200	1150	NA
5.0	1350	1150	1050	NA
5.5	1300	1100	1000	NA
6.0	1200	1000	950	NA
6.5	1150	950	NA	NA
7.0	1100	950	NA	NA

Notes for Tables 6.03 & 6.04

Maximum Span for Single or Double Spans.

Values suitable only when Surround panels are fixed to three or more top hats.

NA Limited by Surround panel span

Cantilever maximum 0.2 x adjacent span

Note: Vertical ExpressWall Top Hats and Intermediate Top Hats connection to horizontal H515 Top Hat or structural steel support of minimum 1.15mm BMT use 2 x 12g-14TPI x 20mm. In Cyclonic conditions, use 1.15mm BMT ExpressWall Top Hats with 14g hex head screws.

FIGURE 6.04 Double Top Hat Span Installation

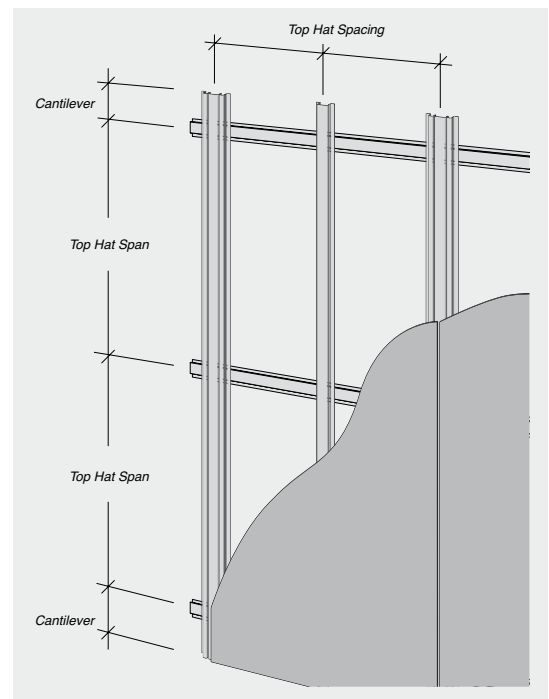



SYSTEM ENGINEERING

Panel Fixing Requirements

FIGURE 6.07 Vertical Sheet Fixing

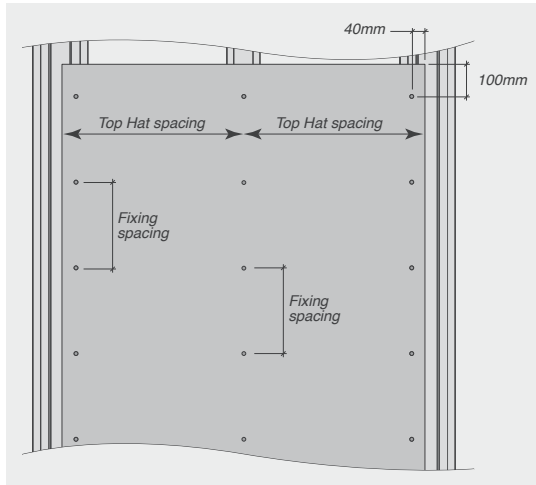

FIGURE 6.08 Horizontal Sheet Fixing

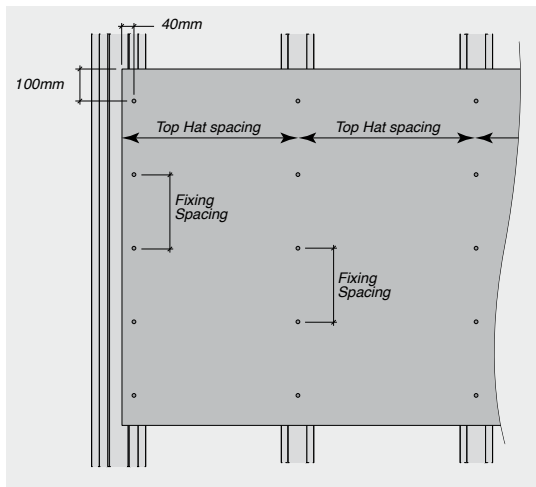

FIGURE 6.05 Panel Fixed to Two Top Hats Only

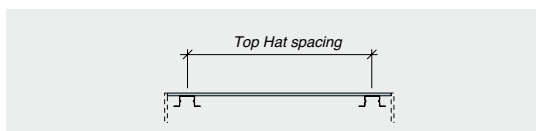
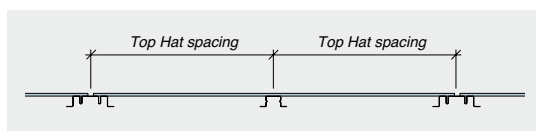

FIGURE 6.06 Panel Fixed to Three or More Top Hats



Note: Surround panels fixed to vertical ExpressWall Top Hats and Intermediate Top Hats using Surround stainless steel rivet fasteners (4 x 18mm shaft, 15mm head).

Panel Fixing Requirements – RESIDENTIAL – BCA Classes 1 and 10 - General & Corner Zones

TABLE 6.05

Wind Classification (AS4055)	Panel Fixing Requirements and Maximum Top Hat Spacings			
	General Zones		Corner Zones	
	Max. Top Hat Spacing (mm)	Max. Fixing Spacing (mm)	Max. Top Hat Spacing (mm)	Max. Fixing Spacing (mm)
N1	600	600	600	600
N2	600	600	600	550
N3/C1	600	600	500	450
N4/C2	600	550	400	350
N5/C3	400	400	400	300
N6/C4	400	300	300	250

Panels fixed to Two & Three or More Top Hats

Panel Fixing Requirements – COMMERCIAL – BCA Classes 2-9

TABLE 6.06

Design Wind Pressure (Ultimate) kPa	Panel Fixing Requirements and Maximum Top Hat Spacings		
	Max. Top Hat Spacing (mm)		Max. Fixing Spacing (mm)
	Panel Fixed to Two Top Hats	Panel Fixed to Three or more Top Hats	At ExpressWall and Intermediate Top Hats
1.0	600	600	600
1.5	600	600	550
2.0	500	600	450
2.5	500	600	400
3.0	400	600	350
3.5	400	400	300
4.0	400	400	300
4.5	400	400	300
5.0	400	400	250
5.5	300	400	250
6.0	300	400	250
6.5	300	400	200
7.0	300	400	200

SYSTEM ENGINEERING





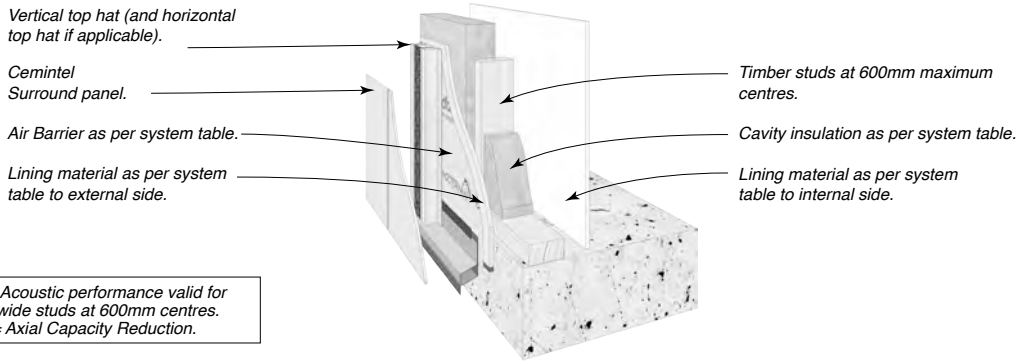

Fire, Acoustic & Thermal Solutions

TABLE 6.07 Timber Frame Expressed Joint Façade – Pressure Equalised Ventilated Cavity System

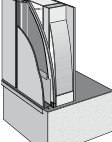
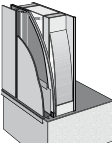
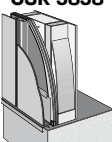

NOTE: Acoustic performance valid for 35mm wide studs at 600mm centres.
*ACR = Axial Capacity Reduction.

SYSTEM SPECIFICATION			ACOUSTIC OPINION PKA-A119					
FRL Report/Opinion	SYSTEM NO	WALL LININGS	STUD DEPTH mm	90	THERMAL*			
			CAVITY INFILL (Refer to Section B)	Rw / Rw+Ctr	ProctorWrap Rt(SUM)	Wall Wrap XP Rt(WIN)	ProctorWrap Rt(SUM)	Wall Wrap XP Rt(WIN)
30/30/30 (from outside only) FAR2303	 CSR 5851 EXTERNAL WALL SIDE • 1 x 16mm Gyprock Fyrchek MR Plasterboard INTERNAL WALL SIDE • 1 x 6mm CeminSeal Wallboard.	(a) 75 Gold Batts R1.5	46/36	2.0	2.2	2.5	2.7	
		(b) 90 Gold Batts R2.0	46/36	2.3	2.5	2.8	3.1	
		(c) 90 Gold Batts R2.5	47/37	2.8	3.1	3.3	3.6	
		Wall Thickness mm	155-170					
30/30/30 (from both sides) FAR2303	 CSR 5854 EXTERNAL WALL SIDE • 1 x 13mm Gyprock Fyrchek MR Plasterboard. INTERNAL WALL SIDE • 1 x 13mm Gyprock Fyrchek Plasterboard.	(a) 75 Gold Batts R1.5	45/34	2.1	2.2	2.5	2.8	
		(b) 90 Gold Batts R2.0	45/34	2.4	2.6	2.9	3.2	
		(c) 90 Gold Batts R2.5	46/35	2.9	3.1	3.3	3.7	
		Wall Thickness mm	159-174					
90/90/90 (from outside only) FAR2303	 CSR 5858 EXTERNAL WALL SIDE • 2 x 13mm Gyprock Fyrchek MR Plasterboard. INTERNAL WALL SIDE • 1 x 10mm Gyprock Plus Plasterboard.	(a) 75 Gold Batts R1.5	46/35	2.1	2.3	2.6	2.9	
		(b) 90 Gold Batts R2.0	46/35	2.5	2.6	2.9	3.2	
		(c) 90 Gold Batts R2.5	47/36	2.9	3.2	3.4	3.8	
		Wall Thickness mm	169-184					
60/60/60* (from outside only) *ACR Group 2 FAR2303	 CSR 5860 EXTERNAL WALL SIDE • 1 x 16mm Gyprock Fyrchek MR Plasterboard. INTERNAL WALL SIDE • 1 x 10mm Gyprock Plus Plasterboard.	(a) 75 Gold Batts R1.5	43/32	2.1	2.2	2.5	2.8	
		(b) 90 Gold Batts R2.0	43/32	2.4	2.6	2.9	3.2	
		(c) 90 Gold Batts R2.5	44/33	2.7	3.1	3.3	3.7	
		Wall Thickness mm	159-174					
60/60/60* (from outside only) *ACR Group 2 FAR2303	 CSR 5862 EXTERNAL WALL SIDE • 1 x 16mm Gyprock Fyrchek MR Plasterboard. INTERNAL WALL SIDE • 1 x 10mm Gyprock Aquachek Plasterboard.	(a) 75 Gold Batts R1.5	45/34	2.1	2.2	2.5	2.8	
		(b) 90 Gold Batts R2.0	45/34	2.4	2.6	2.9	3.2	
		(c) 90 Gold Batts R2.5	46/35	2.7	3.1	3.3	3.7	
		Wall Thickness mm	159-174					
60/60/60 (from both sides) FAR2303	 CSR 5865 EXTERNAL WALL SIDE • 1 x 16mm Gyprock Fyrchek MR Plasterboard. INTERNAL WALL SIDE • 1 x 16mm Gyprock Fyrchek Plasterboard.	(a) 75 Gold Batts R1.5	47/37	2.1	2.2	2.5	2.8	
		(b) 90 Gold Batts R2.0	47/37	2.4	2.6	2.9	3.2	
		(c) 90 Gold Batts R2.5	48/38	2.9	3.1	3.3	3.7	
		Wall Thickness mm	165-180					

* The values presented are calculated through the wall with no thermal bridging paths. They may be used for comparative purposes only.





SYSTEM ENGINEERING

Fire, Acoustic & Thermal Solutions

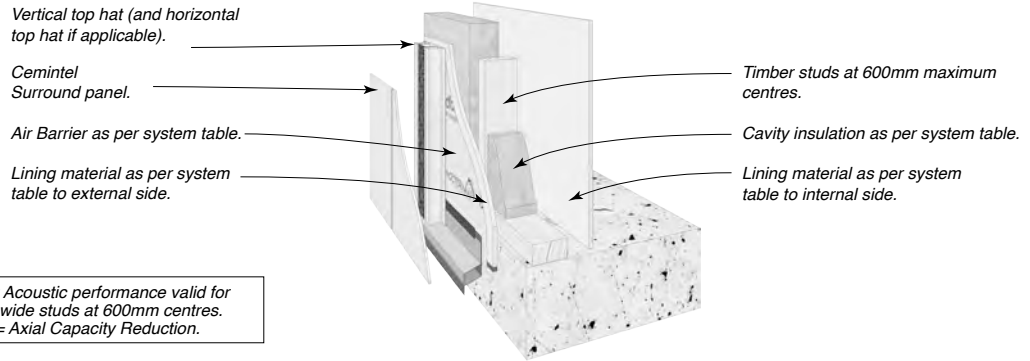
TABLE 6.08 Timber Frame Expressed Joint Façade – Pressure Equalised Ventilated Cavity System

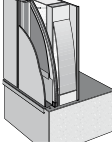
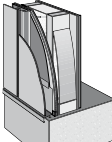

SYSTEM SPECIFICATION			ACOUSTIC OPINION PKA-A119					
FRL Report/Opinion	SYSTEM NO	WALL LININGS	STUD DEPTH mm	90	THERMAL*			
			CAVITY INFILL (Refer to Section B)	Rw / Rw+Ctr	ProctorWrap		Wall Wrap XP	
					Rt(SUM)	Rt(WIN)	Rt(SUM)	Rt(WIN)
60/60/60 90/90/90* (from both sides) *ACR Group 3 FAR2303	 CSR 5868	EXTERNAL WALL SIDE • 1 x 16mm Gyprock Fyrchek MR Plasterboard. • 1 x 6mm CeminSeal Wallboard. (against frame) INTERNAL WALL SIDE • 1 x 16mm Gyprock Fyrchek Plasterboard.	(a) 75 Gold Batts R1.5	49/39	2.1	2.2	2.6	2.8
			(b) 90 Gold Batts R2.0	49/39	2.4	2.6	2.9	3.2
			(c) 90 Gold Batts R2.5	50/40	2.9	3.1	3.4	3.7
			Wall Thickness mm	171-186				
90/90/90* (from both sides) *ACR Group 3 FAR2303	 CSR 5870	EXTERNAL WALL SIDE • 1 x 16mm Gyprock Fyrchek MR Plasterboard. • 1 x 6mm CeminSeal Wallboard. (against frame). INTERNAL WALL SIDE • 2 x 13mm Gyprock Fyrchek Plasterboard.	(a) 75 Gold Batts R1.5	51/42	2.2	2.3	2.6	2.9
			(b) 90 Gold Batts R2.0	51/42	2.5	2.7	3.0	3.3
			(c) 90 Gold Batts R2.5	52/43	3.0	3.2	3.4	3.8
			Wall Thickness mm	181-196				
120/120/120 (from outside only) FAR2303	 CSR 5872	EXTERNAL WALL SIDE • 2 x 16mm Gyprock Fyrchek MR Plasterboard. INTERNAL WALL SIDE • 1 x 10mm Gyprock Plus Plasterboard.	(a) 75 Gold Batts R1.5	47/36	2.1	2.3	2.6	2.9
			(b) 90 Gold Batts R2.0	47/36	2.5	2.6	2.9	3.2
			(c) 90 Gold Batts R2.5	48/37	2.9	3.2	3.4	3.8
			Wall Thickness mm	175-190				
120/120/120 (from both sides) FAR2303	 CSR 5874	EXTERNAL WALL SIDE • 2 x 16mm Gyprock Fyrchek MR Plasterboard. INTERNAL WALL SIDE • 2 x 16mm Gyprock Fyrchek Plasterboard.	(a) 75 Gold Batts R1.5	52/43	2.4	2.6	2.4	3.1
			(b) 90 Gold Batts R2.0	52/43	2.7	2.9	3.2	3.5
			(c) 90 Gold Batts R2.5	53/44	3.0	3.3	3.5	3.8
			Wall Thickness mm	197-212				

* The values presented are calculated through the wall with no thermal bridging paths. They may be used for comparative purposes only.

SYSTEM ENGINEERING



Fire, Acoustic & Thermal Solutions

TABLE 6.09 Steel Frame Expressed Joint Façade – Pressure Equalised Ventilated Cavity System

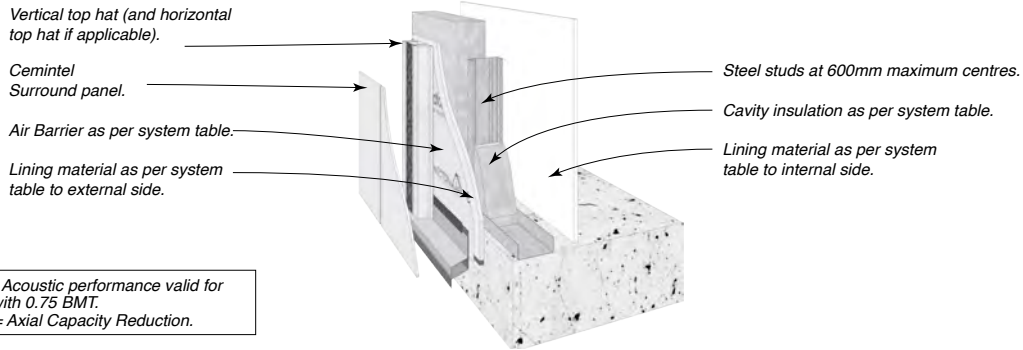

NOTE: Acoustic performance valid for studs with 0.75 BMT.
*ACR = Axial Capacity Reduction.

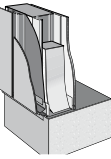
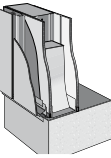
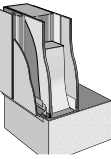
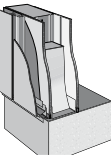
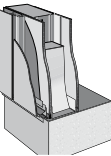
SYSTEM SPECIFICATION			ACOUSTIC OPINION PKA-A119					
FRL Report/Opinion	SYSTEM No	WALL LININGS	STUD DEPTH mm	THERMAL*				
			CAVITY INFILL <small>(Refer to Section B)</small>	Rw / Rw+Ctr	ProctorWrap Rt(SUM) Rt(WIN)		Wall Wrap XP Rt(SUM) Rt(WIN)	
- / - / -	CSR 5327 	EXTERNAL WALL SIDE	(a) 75 Acoustigard R1.7	48/39	2.2	2.3	2.2	2.9
		• Nil	(b) 90 Acoustigard R2.2	49/40	2.5	2.7	3.0	3.3
		INTERNAL WALL SIDE	(c) 90 Acoustigard R2.5	49/40	2.8	3.0	3.3	3.6
		• 1 x 13mm Gyprock Standard Plasterboard.	Wall Thickness mm	146-161				
30/30/30 (from outside only) FAR2357	CSR 5332 	EXTERNAL WALL SIDE	(a) 75 Acoustigard R1.7	43/32	2.3	2.4	2.3	3.0
		• 1 x 13mm Gyprock Fyrchek MR Plasterboard.	(b) 90 Acoustigard R2.2	44/33	2.6	2.8	3.0	3.4
		INTERNAL WALL SIDE	(c) 90 Acoustigard R2.5	44/33	2.9	3.1	3.3	3.7
		• 1 x 10mm Gyprock Plus Plasterboard.	Wall Thickness mm	156-171				
30/30/30 (from outside only) FAR2357	CSR 5340 	EXTERNAL WALL SIDE	(a) 75 Acoustigard R1.7	48/38	2.3	2.4	2.3	3.0
		• 1 x 16mm Gyprock Fyrchek MR Plasterboard.	(b) 90 Acoustigard R2.2	49/39	2.6	2.8	3.0	3.4
		INTERNAL WALL SIDE	(c) 90 Acoustigard R2.5	49/39	2.9	3.1	3.3	3.7
		• 1 x 6mm CeminSeal Wallboard.	Wall Thickness mm	155-170				
60/60/60* (from outside only) *ACR 5% FAR2357	CSR 5342 	EXTERNAL WALL SIDE	(a) 75 Acoustigard R1.7	44/33	2.3	2.4	2.3	3.0
		• 1 x 16mm Gyprock Fyrchek MR Plasterboard.	(b) 90 Acoustigard R2.2	45/34	2.6	2.8	3.0	3.4
		INTERNAL WALL SIDE	(c) 90 Acoustigard R2.5	45/34	2.9	3.1	3.3	3.7
		• 1 x 10mm Gyprock Plus Plasterboard.	Wall Thickness mm	159-174				
60/60/60* (from outside only) *ACR 5% FAR2357	CSR 5343 	EXTERNAL WALL SIDE	(a) 75 Acoustigard R1.7	47/36	2.3	2.4	2.3	3.0
		• 1 x 16mm Gyprock Fyrchek MR Plasterboard.	(b) 90 Acoustigard R2.2	48/37	2.6	2.8	3.0	3.4
		INTERNAL WALL SIDE	(c) 90 Acoustigard R2.5	48/37	2.9	3.1	3.3	3.7
		• 1 x 10mm Gyprock Aquachek Plasterboard.	Wall Thickness mm	159-174				

* The values presented are calculated through the wall with no thermal bridging paths. They may be used for comparative purposes only.





SYSTEM ENGINEERING

Fire, Acoustic & Thermal Solutions

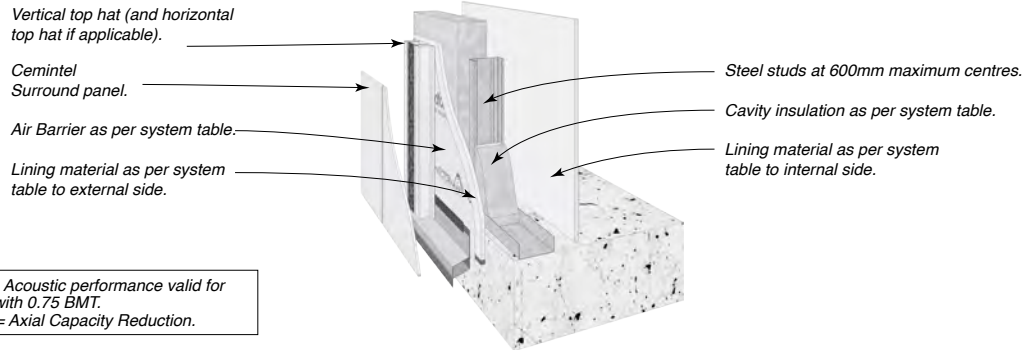
TABLE 6.10 Steel Frame Expressed Joint Façade – Pressure Equalised Ventilated Cavity System

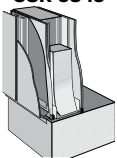
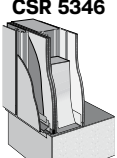

SYSTEM SPECIFICATION			ACOUSTIC OPINION PKA-A119					
FRL Report/Opinion	SYSTEM NO	WALL LININGS	STUD DEPTH mm	90	THERMAL*			
			CAVITY INFILL (Refer to Section B)	Rw / Rw+Ctr	ProctorWrap		Wall Wrap XP	
					Rt(SUM)	Rt(WIN)	Rt(SUM)	Rt(WIN)
60/60/60 90/90/90* (from both sides) *ACR 5% FAR2357	 CSR 5345	EXTERNAL WALL SIDE • 1 x 16mm Gyprock Fyrchek MR Plasterboard. INTERNAL WALL SIDE • 1 x 16mm Gyprock Fyrchek Plasterboard.	(a) 75 Acoustigard R1.7	50/40	2.3	2.4	2.3	3.0
			(b) 90 Acoustigard R2.2	51/41	2.6	2.8	3.1	3.4
			(c) 90 Acoustigard R2.5	51/41	2.9	3.1	3.3	3.7
			Wall Thickness mm	165-180				
90/90/90 (from outside only) FAR2357	 CSR 5346	EXTERNAL WALL SIDE • 2 x 13mm Gyprock Fyrchek MR Plasterboard. INTERNAL WALL SIDE • 1 x 10mm Gyprock Plus Plasterboard.	(a) 75 Acoustigard R1.7	48/37	2.3	2.5	2.3	3.1
			(b) 90 Acoustigard R2.2	49/38	2.6	2.9	3.1	3.4
			(c) 90 Acoustigard R2.5	49/39	2.7	2.9	2.7	2.9
			Wall Thickness mm	169-184				
120/120/120 (from outside only) FAR2357	 CSR 5347	EXTERNAL WALL SIDE • 2 x 16mm Gyprock Fyrchek MR Plasterboard. INTERNAL WALL SIDE • 1 x 10mm Gyprock Plus Plasterboard.	(a) 75 Acoustigard R1.7	49/38	2.3	2.5	2.3	3.1
			(b) 90 Acoustigard R2.2	50/39	2.6	2.9	3.1	3.4
			(c) 90 Acoustigard R2.5	50/39	2.9	3.2	3.4	3.8
			Wall Thickness mm	175-190				
120/120/120 -/180/180 (from both sides) FAR2357	 CSR 5349	EXTERNAL WALL SIDE • 2 x 16mm Gyprock Fyrchek MR Plasterboard. INTERNAL WALL SIDE • 2 x 16mm Gyprock Fyrchek Plasterboard.	(a) 75 Acoustigard R1.7	55/46	2.4	2.6	2.4	3.1
			(b) 90 Acoustigard R2.2	56/47	2.7	2.9	3.2	3.5
			(c) 90 Acoustigard R2.5	56/47	3.0	3.3	3.5	3.8
			Wall Thickness mm	197-212				

* The values presented are calculated through the wall with no thermal bridging paths. They may be used for comparative purposes only.

SYSTEM ENGINEERING



FIGURE 6.09 Typical Surround External Fire Rated Installation.
– Pressure Equalised Ventilated Cavity System

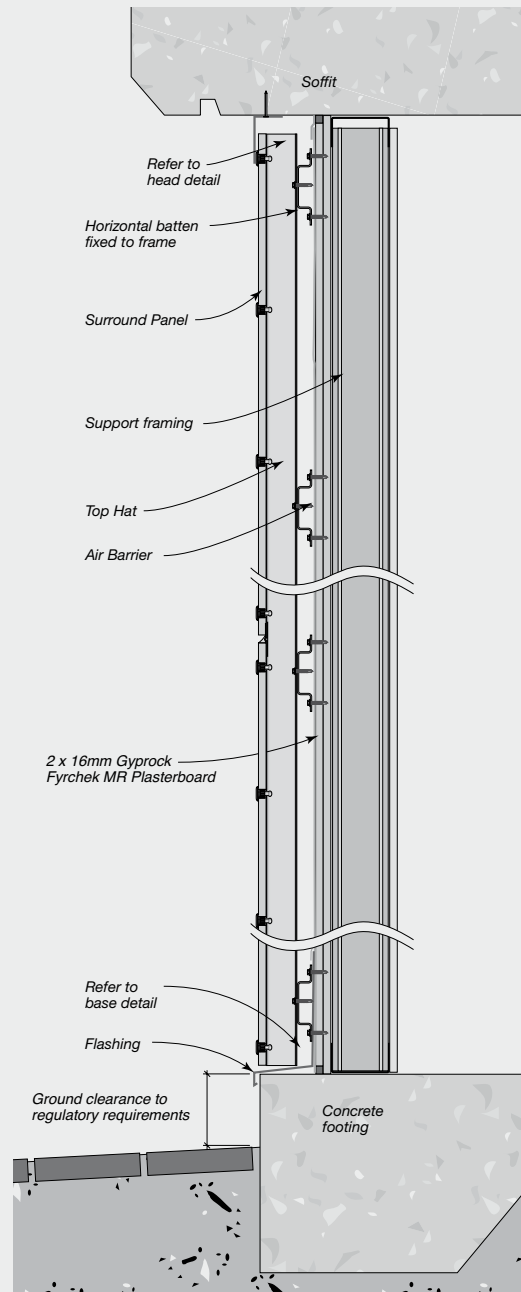

07

INSTALLATION

CHECKLIST – Prior to Installation

The following pre-install checklist may assist to ensure you have the best possible outcome when using Surround External.

- Ensure substrate is straight and plumb. Pack studs to straighten if necessary (timber frames as per AS 1684, steel frames as per AS/NZS 4600). Industry best practice for frame tolerance is 5mm misalignment over 3000mm.
- Ensure studs are correctly located and of the appropriate thickness.
- Confirm bracing is in place. Where sheet bracing is used behind panels, the entire wall area needs to be braced or bracing sheet packers fixed to the frame to ensure a uniform fixing plane.
- Remove any concrete that may foul the cladding line, particularly at steps in slabs and isolated columns.
- Ensure there is adequate ground clearance to the bottom edge of the Surround panels as per regulatory requirements (including for water/rain runoff and termite management). These can vary from 50-150mm depending on type of ground and termite requirements.
- Confirm your panel layout to determine the location of joints and identify where additional studs are required.
- Flashings, membranes and air barrier should be correctly installed, overlapped and taped at joints, prior to fixing panels.
- Install windows so that the back of the front face of the window (or any other protrusions including doors or meter boxes) will be flush with the face of the panels.
- Fit Head flashings over windows, doors and other penetrations.
- Confirm the chosen eaves/soffit details and prepare accordingly.
- Consider the need for structural support for fixtures such as pergolas and balconies. No loads may be carried by the cladding.
- Confirm membranes and flashings for balcony areas have been installed in accordance with manufacturers' specifications.
- Arrange for a pre-cladding inspection by the appropriate local building authority if required.



Check quality and quantity of panels and components before installing. If there is any sign of damage or visible defects in panels, or the colour/finish is not in keeping with the owner's aesthetic requirements DO NOT INSTALL. Contact Cemintel to address any issues.



Installation Set-Out

Appropriate panel fixing layout and top hat spacing should be suitable for the project design wind pressure. It is recommended that fasteners be fixed 100mm from the top and bottom edges of the panel and 40mm in from the side of the panels.

FIGURE 7.01 Horizontal Sheet Fixing

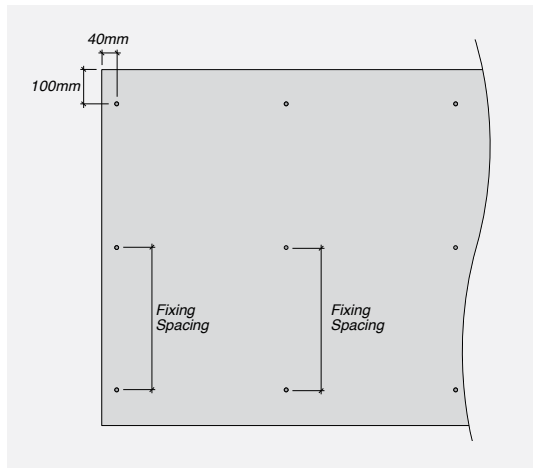
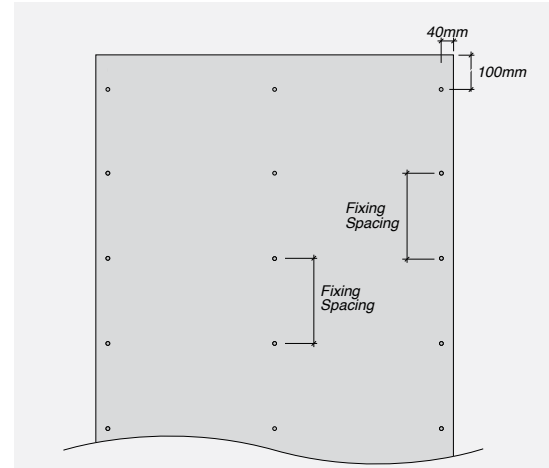

FIGURE 7.02 Vertical Sheet Fixing



Panels must be fixed in accordance with the tables set out in 'System Engineering' Section. This provides fixing Requirements and Maximum Top Hat Spacings for 1200mm wide panels based on 2 top hats or 3 or more top hats.

Installation for Timber and Steel Framing

Refer to 'System Engineering' and 'Construction Drawings and Details' sections for specific fixing information.

Step 1 – Install air barrier – as per Cemintel Air Barrier Installation Guide.

Step 2 – Fix base flashing to base of wall over air barrier (wall wrap or rigid air barrier) taping top edge of flashing to air barrier.

Step 3 – Fix top hats. Fix H515 top hats horizontally where required to substrate as per 'System Engineering' section requirements. Fix ExpressWall and intermediate top hats vertically to H515 framing as per 'System Engineering' section requirements.

Step 4 – Prepare panels. Cut panels as required. Run a fine sandpaper block along the edge of the cut panel (taking care not to scratch the panels surface). Seal cut edges with Cemintel's recommended edge sealant to protect against moisture entering the panels.

Step 5 – Pre-drill panel holes. This should be done prior to lifting panels into place and can be done off site. Panel holes need to be drilled a minimum 100mm from the horizontal edge and a minimum of 40mm from the vertical edge (refer to 'System Engineering Section').

For Surround rivets, use the recommended Cemintel 9.5mm carbide tipped drill bit with centreing tip (Refer Fig. 7.03).

The size of the hole drilled is designed to match the size of the rivet rubber sleeve. The use of other tools for this purpose may reduce fixing capacity and reduce the weather resistance of the system. DO NOT use hammering action when drilling. For efficiency you can neatly stack 3 or 4 sheets and drill through all at the same time. Take care to avoid damaging the panel with the drill chuck when approaching the end of the hole by using a timber block.

Clean/sweep away any dust from holes as this can stick to the panel.

FIGURE 7.03 Pre-drilling Panels – Rivet Fix

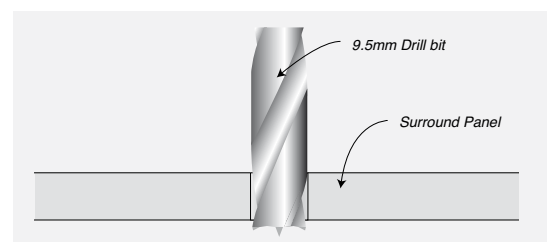

INSTALLATION



Step 6 – Install Vertical gaskets to the ExpressWall Top Hats for the full extent of panels. Take care not to stretch the gasket when installing (Refer Fig. 7.04). When joining gasket, cut ends cleanly and push together before adhering. When top hat is discontinuous, butt ends together tightly and continue gasket over the joint. If a gap is present, install a steel strip to support the gasket (Refer Fig. 7.05).

At the beginning and end of a vertical joint, such as with sheets installed in a half-bond pattern, continue the vertical gasket past the horizontal joint by 100mm minimum (Refer Fig. 7.06).

FIGURE 7.04 Vertical Gasket – Rivet Fixed

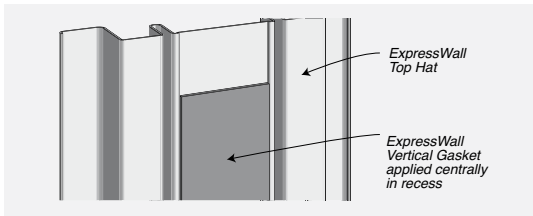

FIGURE 7.05 Gasket Support at Discontinuous Joint – Screw Fixed or Rivet Fixed

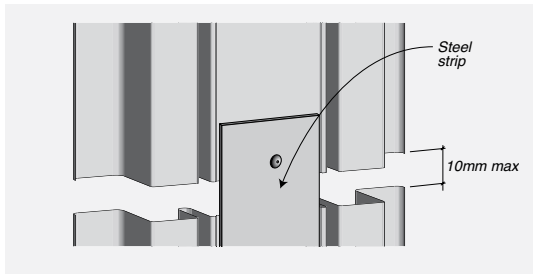

FIGURE 7.06 Vertical Gasket and Fixing Detail for Half-Bond Panel Layout – Rivet Fixed

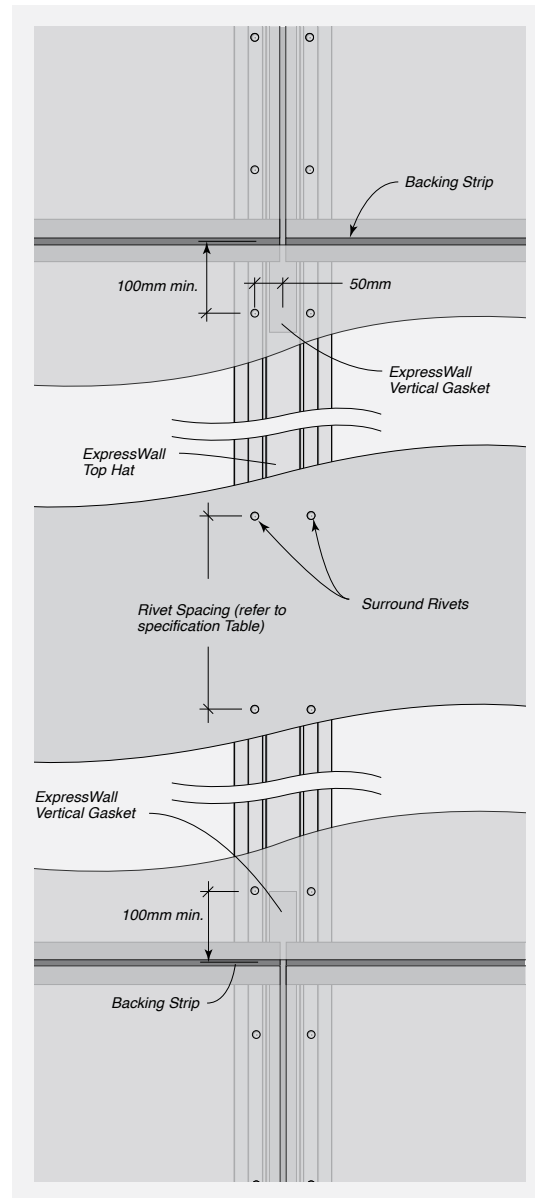
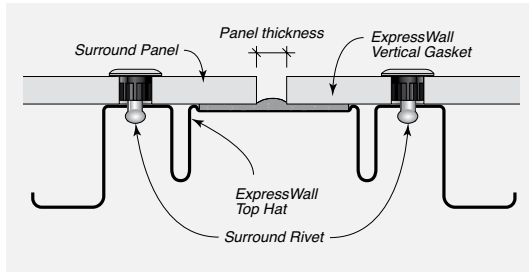
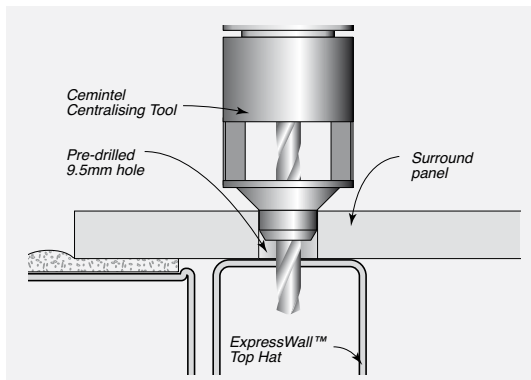
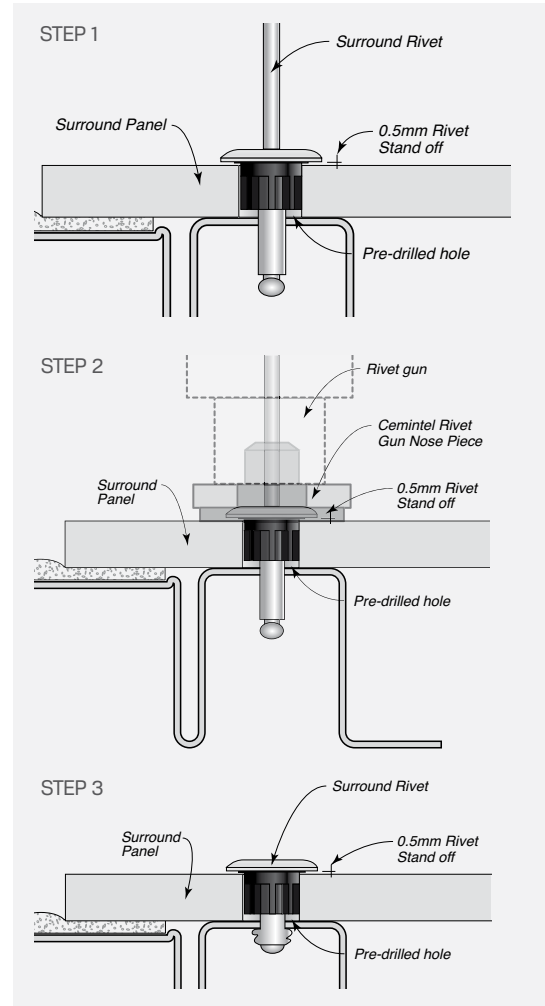
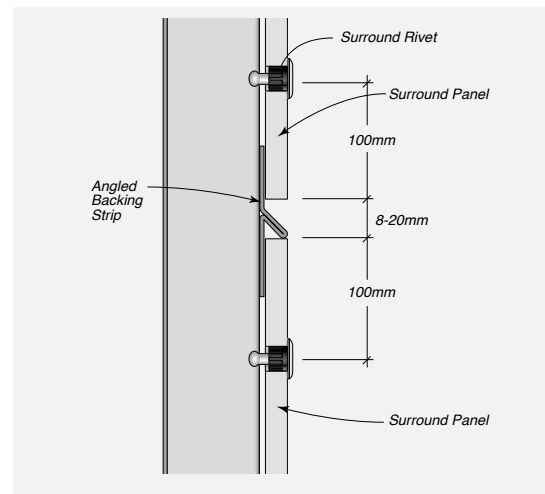

FIGURE 7.07 Vertical Joint Detail – Rivet Fixed**FIGURE 7.08** Centralising Tool**Step 7 – Install wall panels.**

Fixing panel using rivets – Lift panel into place, clamp down level to identify horizontal and vertical planes. Using the Rivet Centralising Tool, drill 4.1mm rivet holes through the pre-drilled panel holes into the top hats. This specialised tool creates a rivet hole, which matches the size of the shaft of the rivet, precisely in the centre of the panel hole (Refer Fig. 7.09).

Install Rivet Gun nose piece onto the Gesipa Accubird battery operated blind rivet gun. The nose piece has a slight concave shape which serves to create a small (0.5mm) clearance between the panel face and the rivet flange. This enables differential movement of the frame while reducing damage to the panel face. Fix panel starting at the bottom corner. Place the rivet gun with the rivet gun head onto the rivet shaft. Push the panel firmly against the framing/gaskets and operate the gun to pull the rivet through panel hole into the predrilled top hat.

Before fixing top rivets to panel, insert Surround Angled Backing Strip along horizontal joint. Clip corners at an angle and bend. Surround Panels are generally installed with a nominal 8-10mm wide expressed joint in both horizontal and vertical directions (a small cut piece of panel can be used as a spacer to easily measure joint widths and ensure consistency). Once positioned, fasten top row of rivets.

FIGURE 7.09 Fixing with Rivets**FIGURE 7.10** Horizontal Joint with Angled Backing Strip

INSTALLATION



When using the ExpressWall backing strip, ensure ExpressWall backing strip is 6mm shorter overall than the width of the panel (cut to length if necessary).

A fillet of Sikaflex 11FC is then placed along the top edge of the panel. This ensures that the joint drains and salt and dirt do not build up in the joint.

To seal the groove in the backing strip at the ends, apply a small section of gasket to the rear of the backing strip. This will be forced into the recess and seal the end of the strip. Alternatively use Sikaflex 11FC to fill the groove.

Joint widths – While panels are generally installed with a nominal 8-10mm wide horizontal and vertical expressed joint. However joints up to 20mm can be formed provided additional care is taken during installation to ensure that panel edges cover the joint gaskets by a minimum of 10mm.

FIGURE 7.11 Backing Strip Positioning

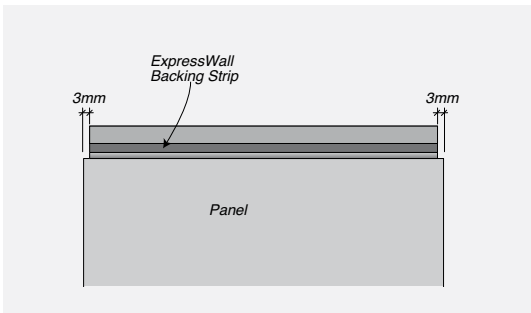

FIGURE 7.12 Horizontal Joint

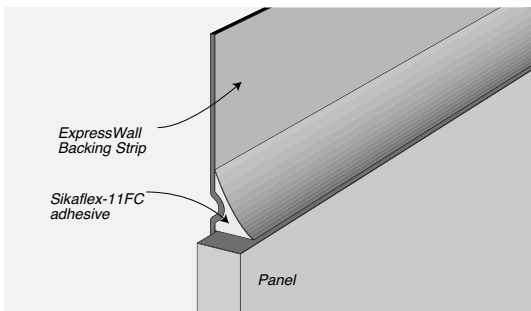

FIGURE 7.14 Vertical Joint

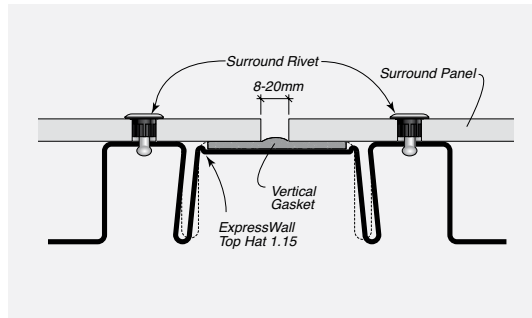

FIGURE 7.13 Sealing Ends of Backing Strip

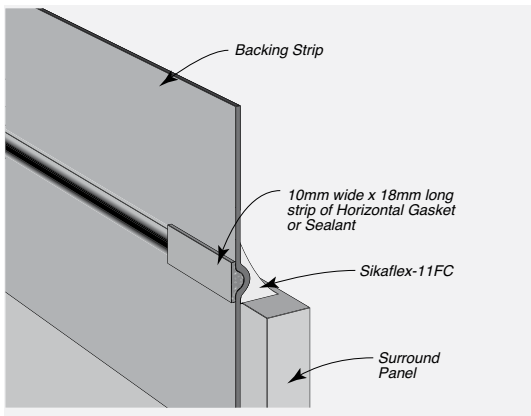
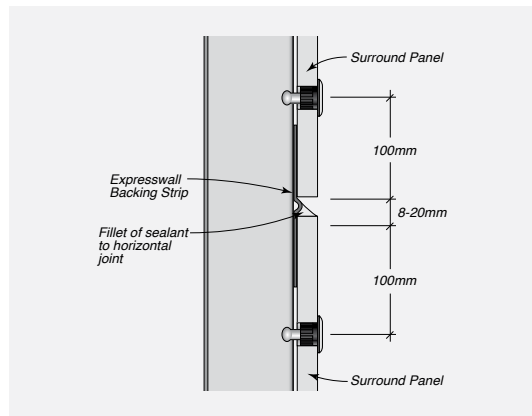

FIGURE 7.15 Horizontal Joint



In certain conditions such as corrosive environments or where there is a preference to have flush sealed joints, horizontal and vertical joints may be filled with recommended joint sealant and in accordance with manufacturer's instructions. Base of walls including horizontal joints at inter-storey junctions must

remain open, to allow pressure equalisation to be maintained and for any water moisture to drain from the cavity. Refer to the sealant filled joint details of the "Construction Drawings and Details" section of this manual.

FIGURE 7.16 Joint Construction – Sealed Option

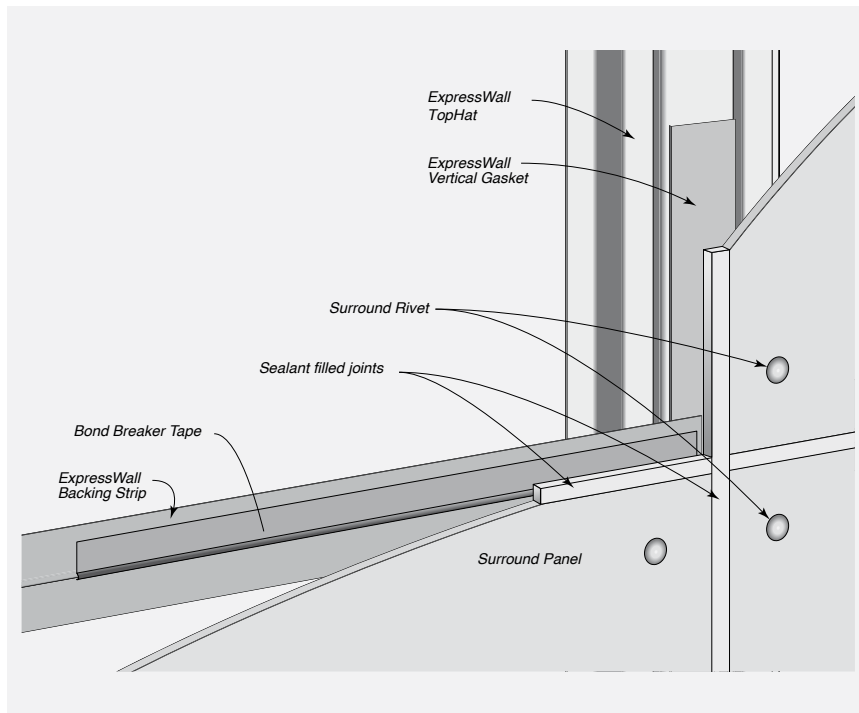

INSTALLATION



FIGURE 7.17 Horizontal Joint Sealed Side

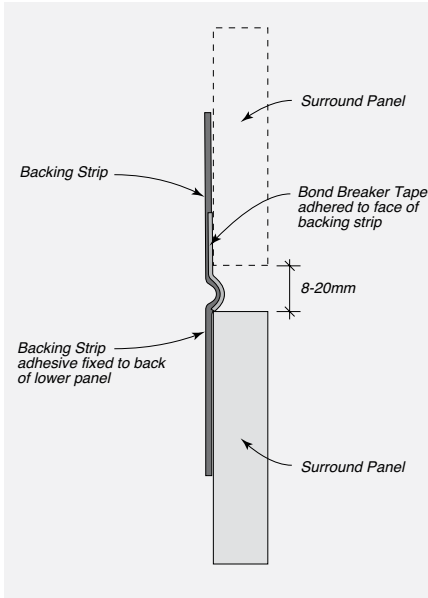

FIGURE 7.20 Horizontal Joint Sealed Side

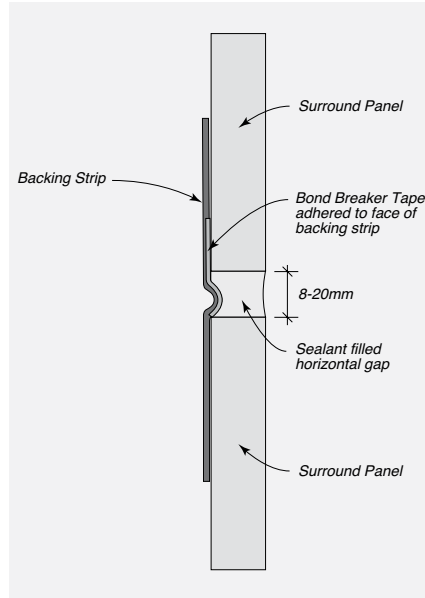

FIGURE 7.21 Backing Strip & Bond Breaker Tape

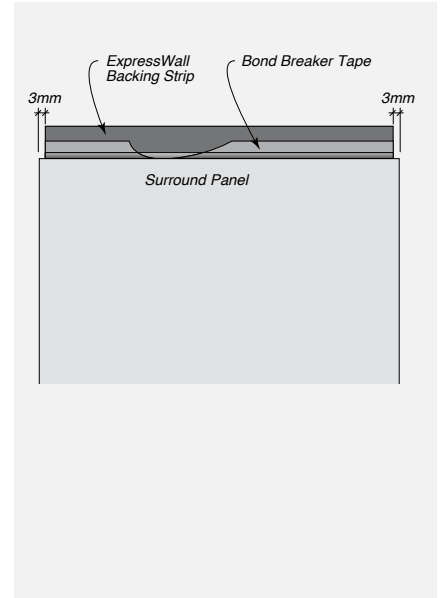

FIGURE 7.18 Horizontal Joint Fixing – Sealed Option

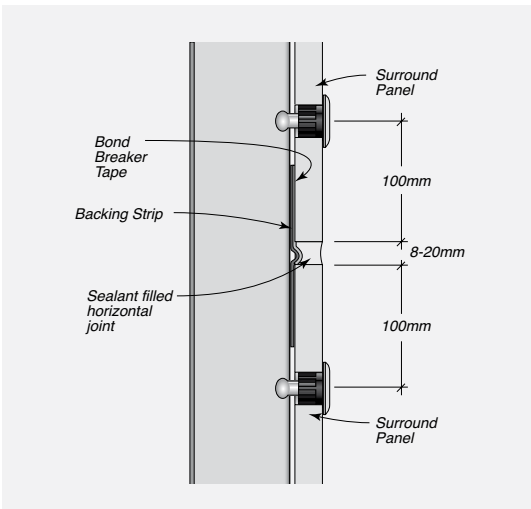
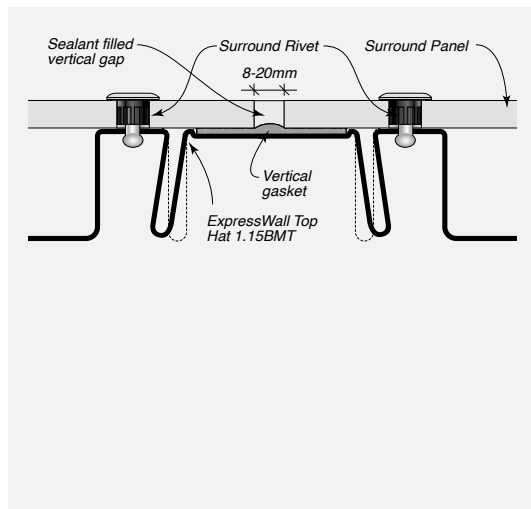

FIGURE 7.19 Vertical Joint – Sealed Option



07

INSTALLATION

Procedure for Installation of Cemintel Rigid Air Barrier™

The Cemintel Rigid Air Barrier may be installed horizontally or vertically across the frame. An appropriate panel fixing layout should be selected for the project design wind pressure and frame spacing. Panels must be fixed in accordance with the tables set out in the 'System Engineering' Section.

Panels are fixed to timber framing using nails to steel framing using screws. A small joint (maximum 3mm) is acceptable. Joints are taped using HighTack tape to form an air barrier. Similarly, all corners, penetrations and junctions are sealed with HighTack tape or with flexible sealant.

All flashings should be fixed over the top of the Rigid Air Barrier and taped with HighTack tape.

Procedure for horizontal or vertical sheet application

- 1 Cut sheets to ensure vertical joints are supported by studs and horizontal joints are backed by noggings
- 2 Position sheets (refer to Head & Base details in 'Construction Drawings & Details' section). Screw fix (to steel frame) or nail (to timber frame) at the detailed fastener centres. (Refer to Tables 6.02 to 6.05 in 'System Engineering Section').
- 3 Install adjacent sheets.
- 4 Seal vertical joints, horizontal joints, and corners with ProctorWrap™ HighTack tape. Seal junctions and penetrations with Sikaflex Pro flexible sealant.
- 5 Seal any openings in head, sill and jamb framing with ProctorWrap™ HighTack tape.
- 6 Apply ProctorWrap™ SLS FlexiTape to corners of window and door openings.



Check quality and quantity of panels and components before installing. If there is any sign of damage or visible defects in panels **DO NOT INSTALL**. Contact Cemintel to address any issues.

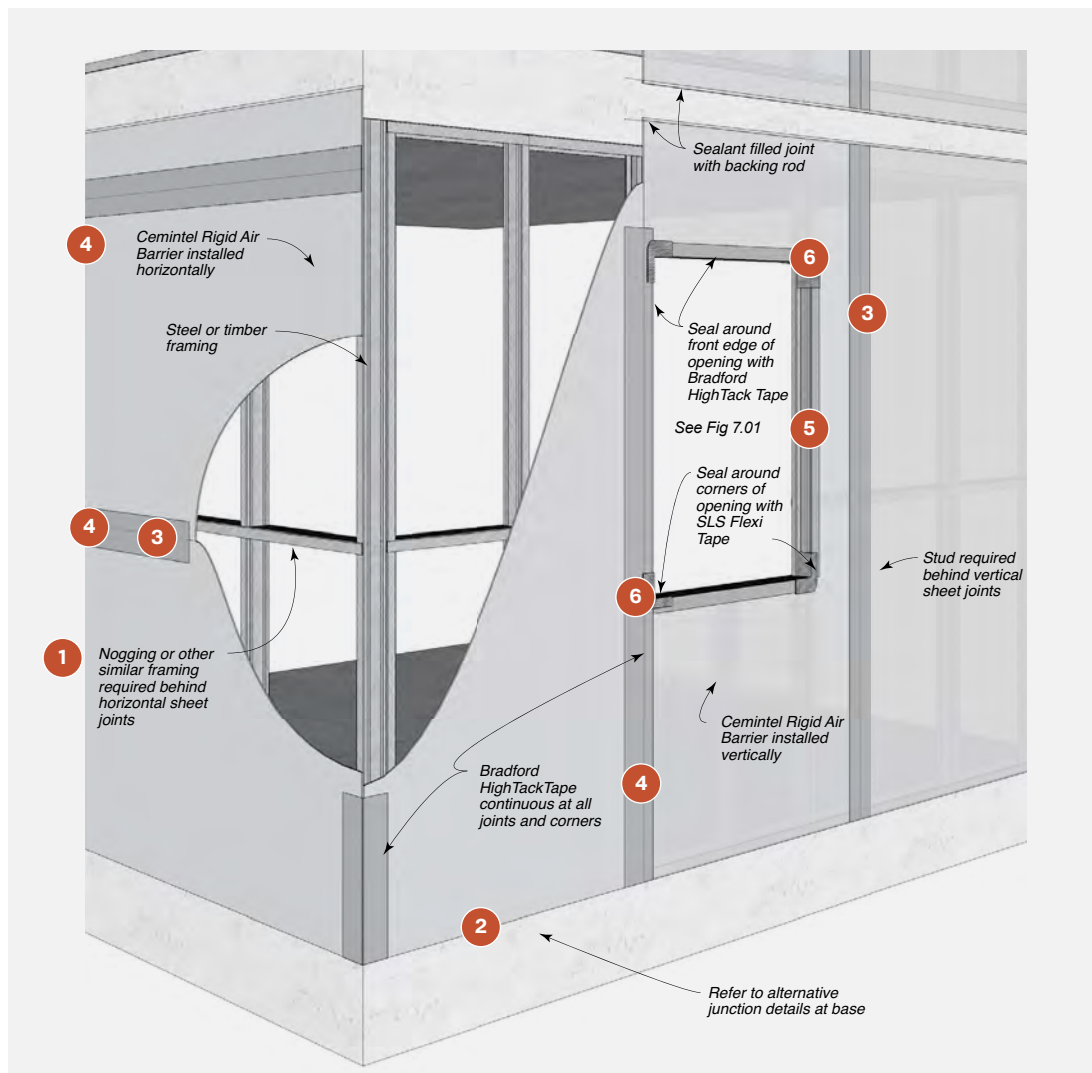

INSTALLATION

07

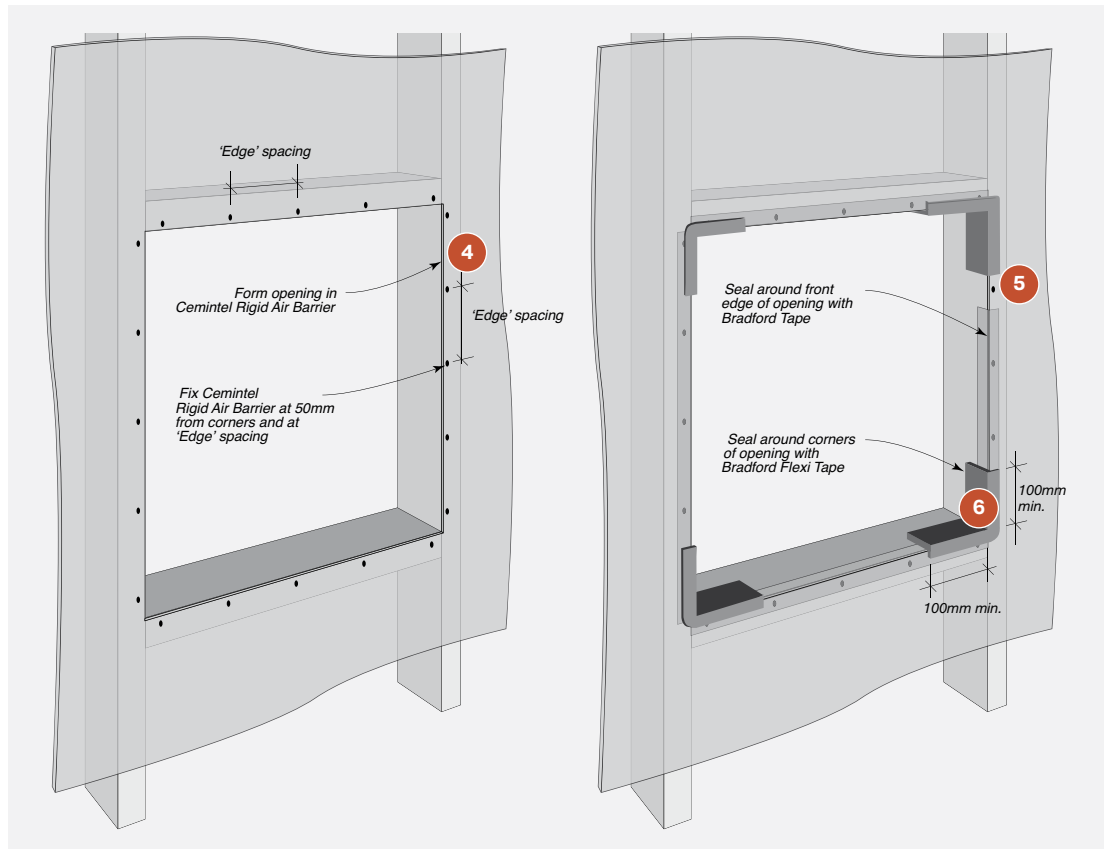
FIGURE 7.22 Treatment at Window/Door Openings – Rigid Air Barrier

Installation of Soft Air Barriers

Wall wraps intended to be used as air barriers are fixed to timber or steel. In the case of Enviroseal™ ProctorWrap™ CW, ends must be overlapped by at least 150mm and taped continuously across horizontal and vertical joints to maintain an air seal. Enviroseal™ ProctorWrap™ CW-IT has an inbuilt adhesive strip which allows fast, consistent and reliable sealing to adjoining rolls of CW-IT.

At internal corners, penetrations and perimeters of areas with wall wrap, a metal strip is required to restrain the wall wrap edges. The wall wrap is then folded over and taped to the main body wrap with HighTack Tape. As detailed, sealant or tape is to be applied to maintain an effective air seal.

All flashings should be fixed over the top of the wall wrap and taped.

Procedure for installation of Soft Air Barriers

- 1 Install wall wrap/sarking to outside face of timber or steel wall framing using Bradford Plasti-Grip Washers at 600mm maximum centres. Horizontal laps must be overlapped by 150mm. Note that Enviroseal™ ProctorWrap™ CW-IT has an inbuilt adhesive strip which allows fast, consistent and reliable sealing to adjoining rolls of CW-IT.
- 2 Install aluminium strips horizontally at head and base of wall. Pass wall wrap under aluminium strip and fix strip at 100mm max. cts. Then fold wall wrap back over strip and tape with HighTack tape to main body.

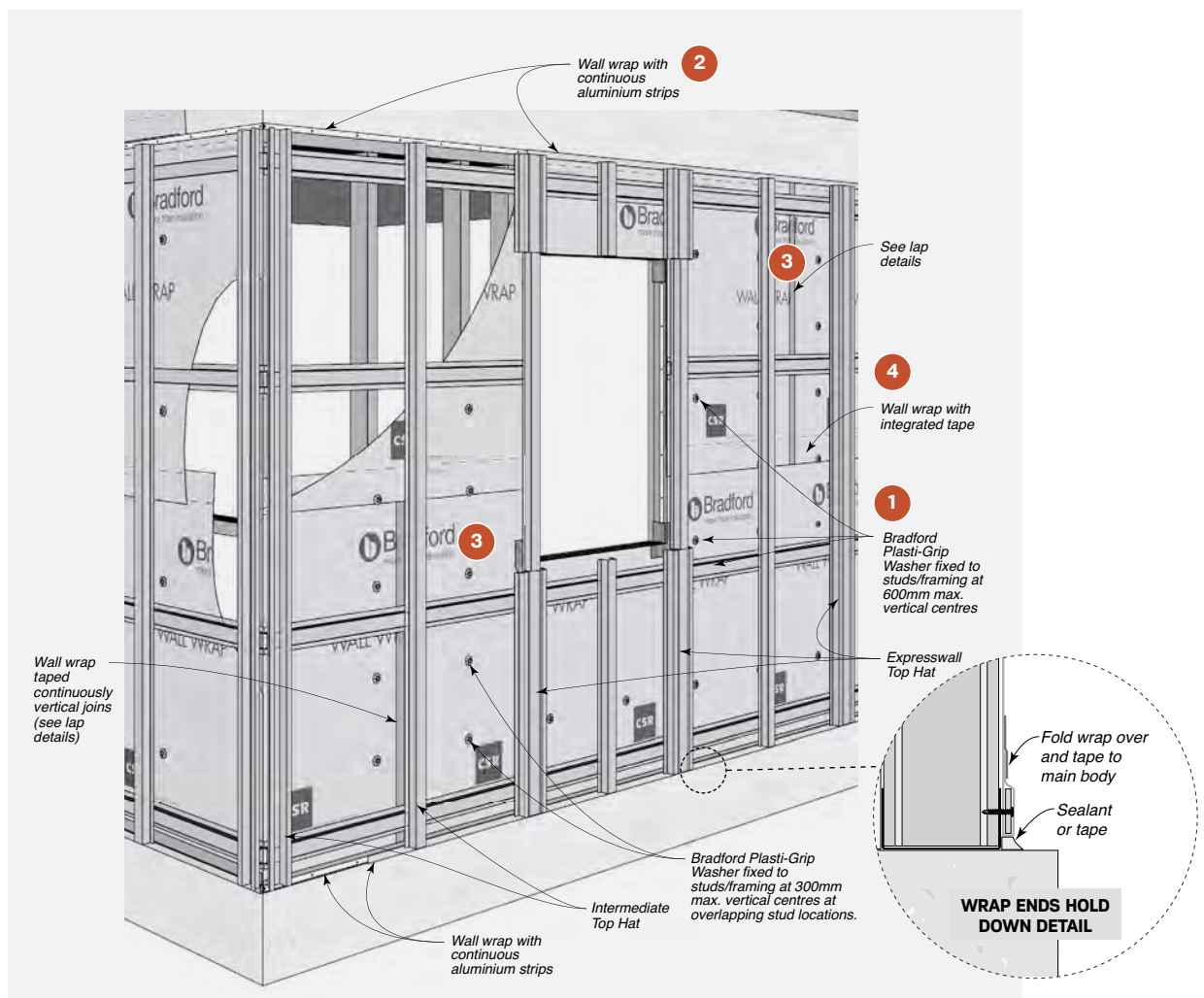

INSTALLATION

07

- 3 Install aluminium strips at vertical joints/ends/corners (where required). Pass wall wrap under aluminium strip and fix at 100mm max cts. Fold wall wrap back over strip and tape with HighTack tape to main body.
- 4 Enviroseal™ ProctorWrap™ CW-IT to be overlapped at horizontal joints and taped continuously with in-built adhesive strip. Vertical lap joints to be overlapped across adjoining studs, fixed with Bradford Plasti-Grip Washers at 300mm maximum centres and taped with HighTack tape along overlap joint.
- 5 At openings, cut the wrap at 45 degrees from each corner to the centre.
- 6 Pass wall wrap under aluminium strip and fix at 100mm max. cts. Then fold wall wrap back over strip and tape with HighTack tape, cutting away any excess wall wrap.
- 7 Apply SLS Flexi Tape to the corners of window and door openings. Press tape over the frame edge onto the face of the wall wrap.

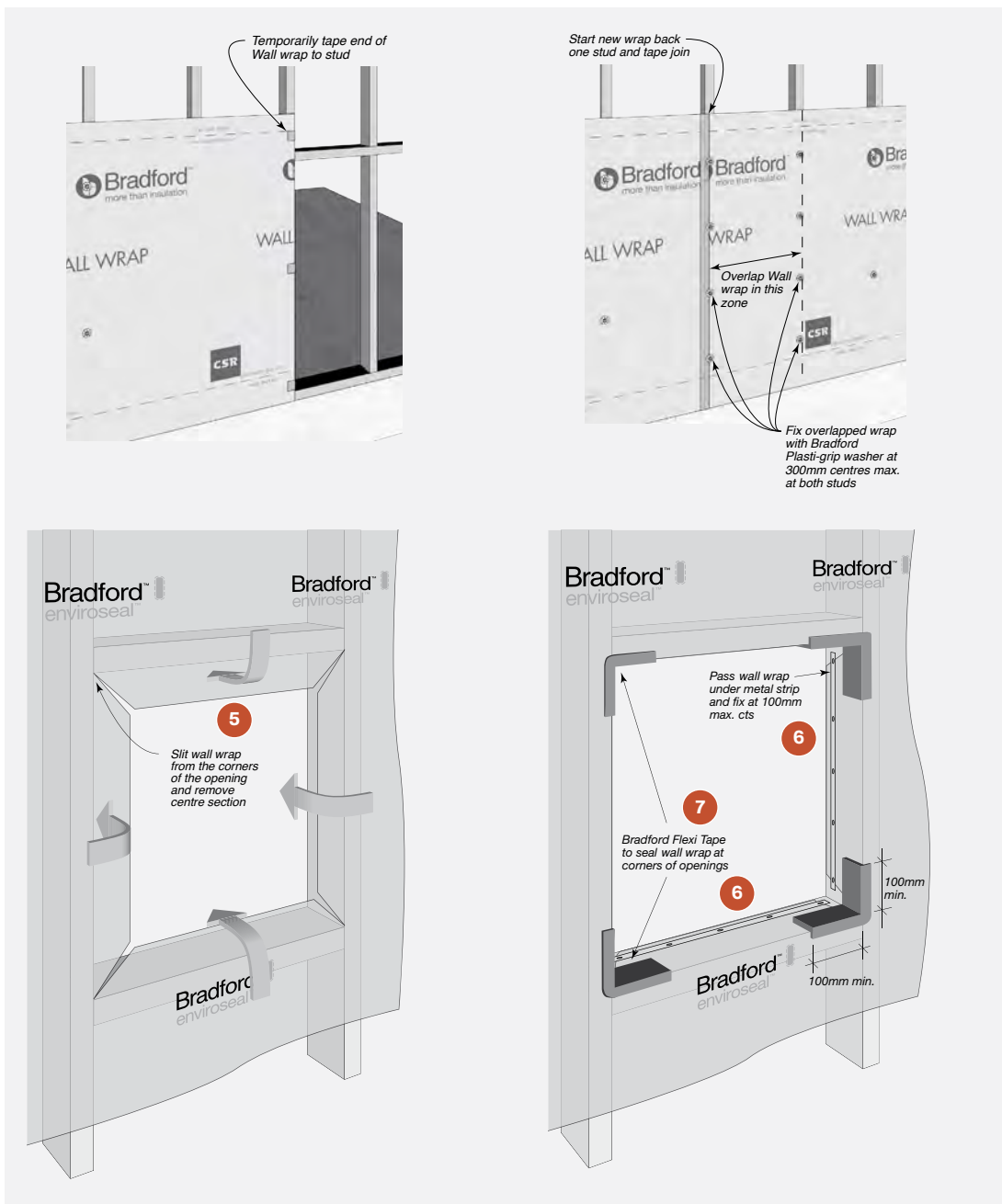



CONSTRUCTION
DRAWINGS + DETAILS

CONSTRUCTION DRAWINGS AND DETAILS



Note: Drawings are interchangeable for timber or steel substrates with the exception of the fasteners.

Drawings Index

SECTION	DESCRIPTION	FIGURE REFERENCE	PAGE NUMBER
VENTILATED CAVITY SYSTEM			
Overview	Joint Construction – Ventilated Cavity System	8.01	52
Joint Details	Horizontal Joint – Sealant Filled	8.02	53
	Horizontal Joint – Angled Backing Strip	8.03	53
	Vertical Joint – Rivet	8.04	53
Cross Section Details	Typical ExpressWall System Cross Section for Steel Framing	8.05	54
Head Details	Eaves/Deflection Head – Ventilated	8.06	54
Base Details	Base Detail – Drained	8.07	54
Corner Details	External Corner	8.08	55
	External Corner – Obtuse Angle	8.09	55
	Internal Corner Detail	8.10	55
Junction Details	Framed Soffit	8.11	56
	Control Joint – Vertical	8.12	56
	Inter-Storey Junction with Flashing	8.13	56
	Inter-Storey Junction with Alternate Flashing	8.14	56
	Inter-Storey Junction with Flashing	8.15	57
	Inter-Storey Junction with Alternate Flashing	8.16	57
	Abutment	8.17	58
	Vertical Gasket and Fixing Detail for Half-bond Panel Layout	8.18	58
Window Details	Typical Window Installation	8.19	58
Parapet Capping	Parapet Capping	8.20	59
Balcony Details	Balcony Base	8.21	59
Drain	Typical Drain	8.22	59
Power/Meter Box Details	Typical Power/Meter Box	8.23	60
VENTILATED CAVITY SYSTEM – SEALANT FILLED JOINT DETAILS			
Overview	Sealant Filled Joint Construction – Ventilated Cavity System	8.24	61
Joint Details – Sealant filled	Backing Strip Preparation	8.25	61
	Horizontal Joint – Sealant filled	8.26	61
	Vertical Joint – Sealant filled	8.27	61
Cross Section Details – Sealant filled	Typical ExpressWall System Cross Section for Steel Framing – Joints sealant filled	8.28	62
Head Detail – Sealant filled	Eaves/Deflection Head – Sealant filled	8.29	62
Base Detail – Drained	Base Detail – Drained	8.30	62
Corner Details – Sealant filled	Internal Corner Detail – Sealant filled	8.31	63
	External Corner – Sealant filled	8.32	63



CONSTRUCTION DRAWINGS AND DETAILS

Note: Drawings are interchangeable for timber or steel substrates with the exception of the fasteners.

Pressure Equalised – Ventilated Cavity System

FIGURE 8.01 Joint Construction -Ventilated Cavity System

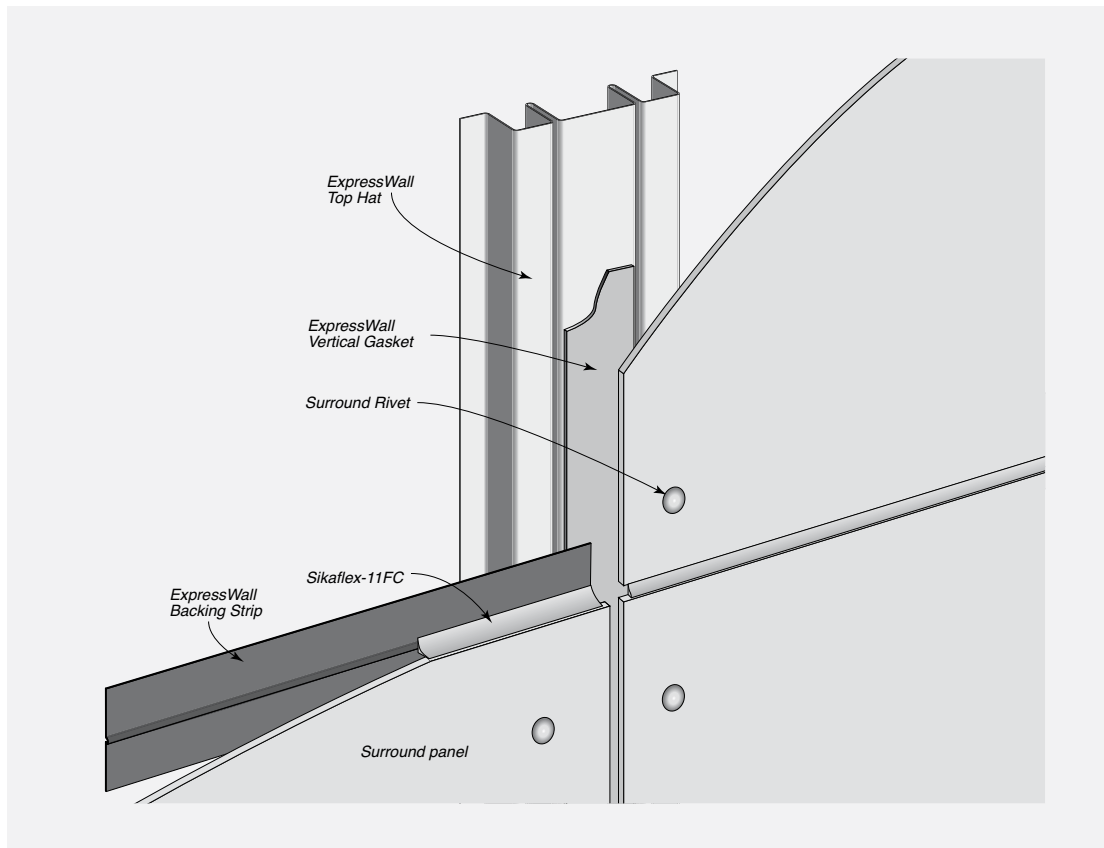

CONSTRUCTION DRAWINGS AND DETAILS



Note: Drawings are interchangeable for timber or steel substrates with the exception of the fasteners.

Pressure Equalised – Ventilated Cavity System

FIGURE 8.02 Horizontal Joint – Sealant Filled

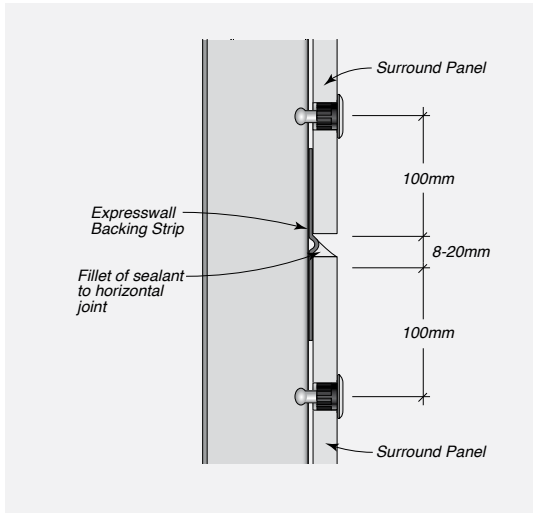

FIGURE 8.03 Horizontal Joint – Angled Backing Strip

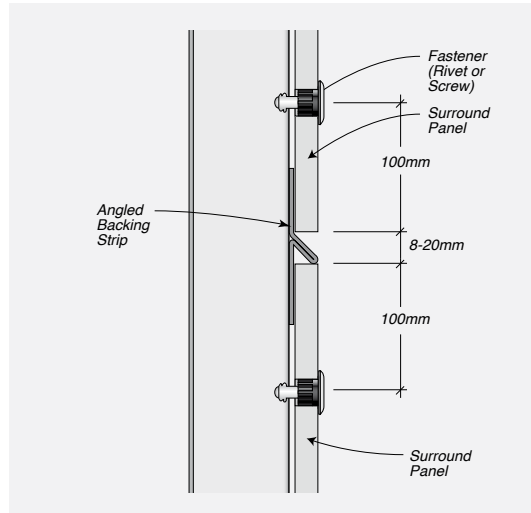
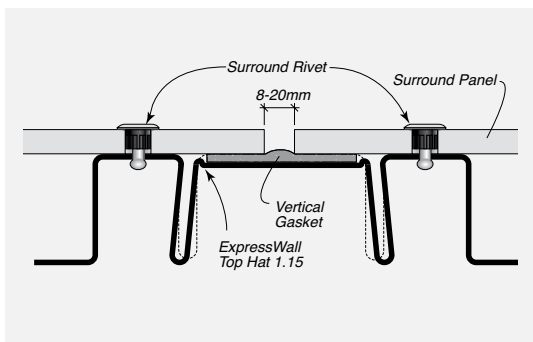

FIGURE 8.04 Vertical Joint – Rivet





CONSTRUCTION DRAWINGS AND DETAILS

Note: Drawings are interchangeable for timber or steel substrates with the exception of the fasteners.

Pressure Equalised – Ventilated Cavity System

FIGURE 8.05 Typical ExpressWall System Cross Section for Steel Framing

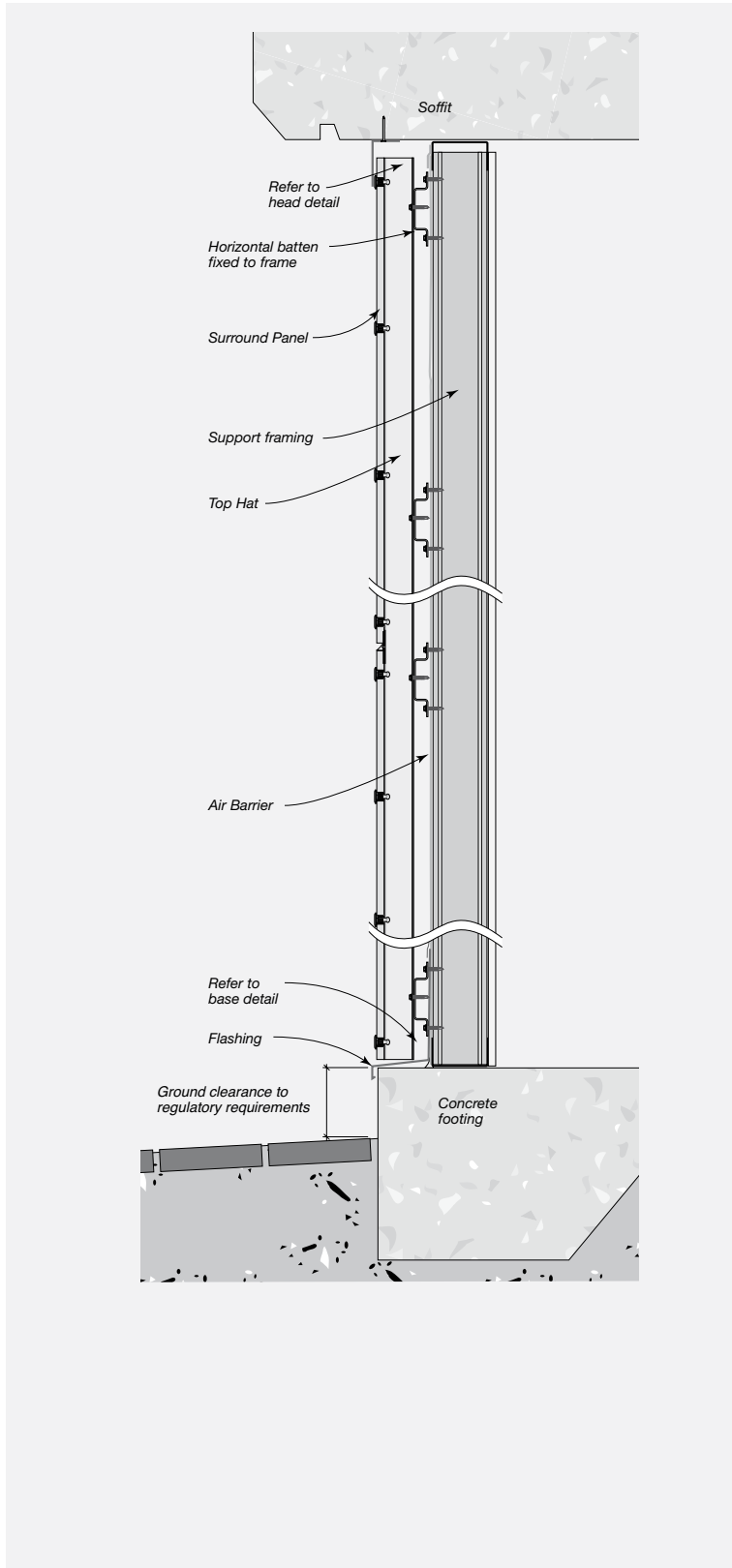

FIGURE 8.06 Eaves/Deflection Head – Ventilated

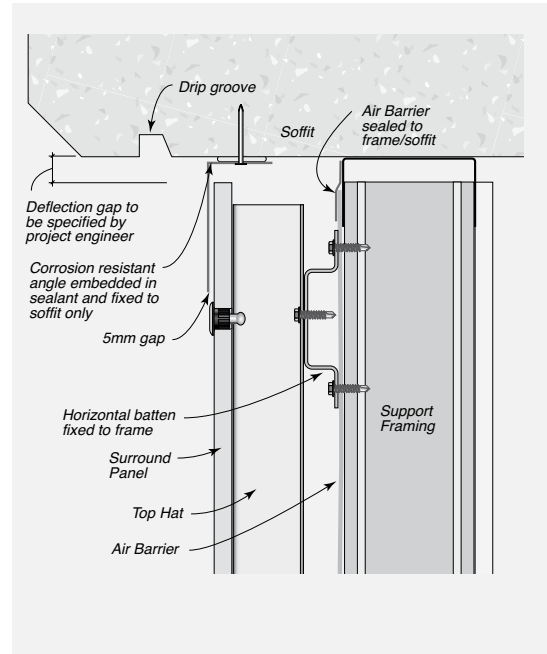
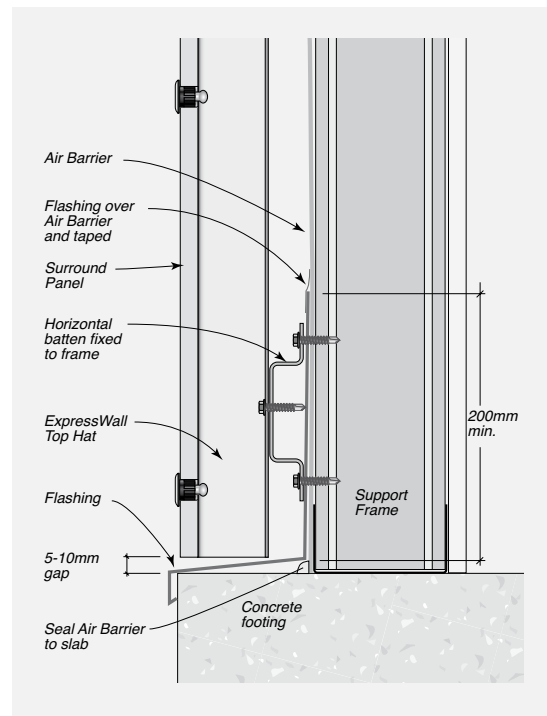

FIGURE 8.07 Base Detail – Drained



CONSTRUCTION DRAWINGS AND DETAILS



Note: Drawings are interchangeable for timber or steel substrates with the exception of the fasteners.

Pressure Equalised – Ventilated Cavity System

FIGURE 8.08 External Corner

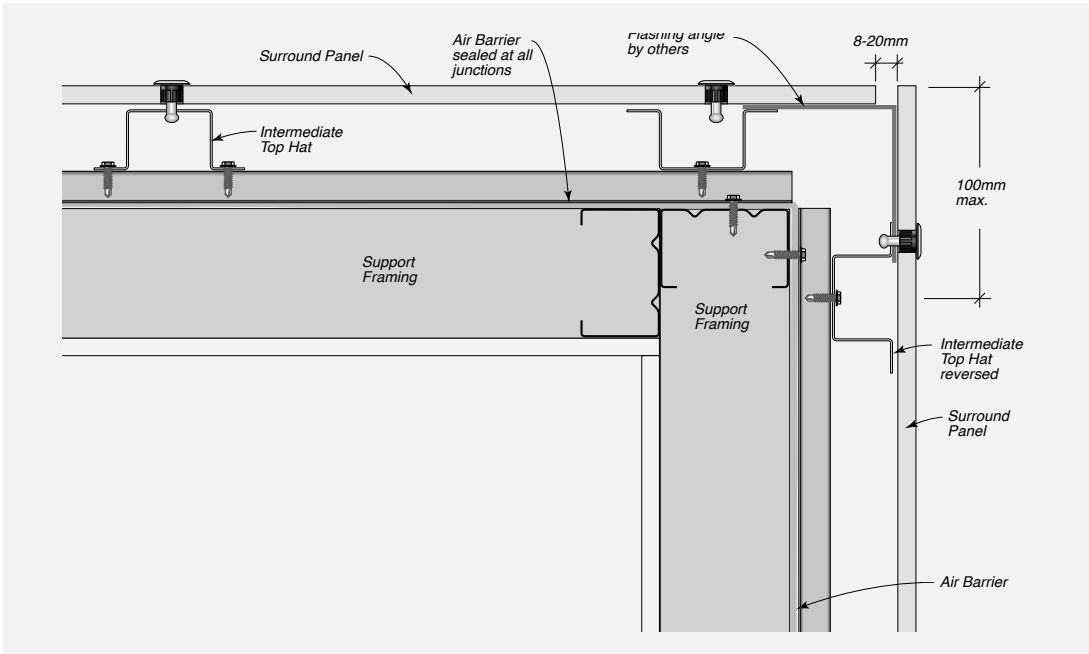

FIGURE 8.09 External Corner – Obtuse Angle

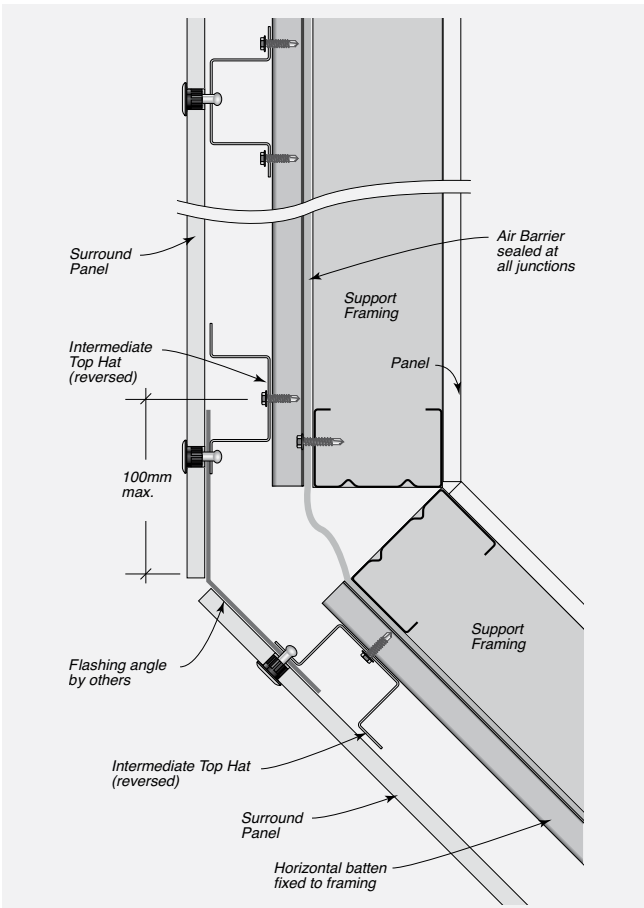
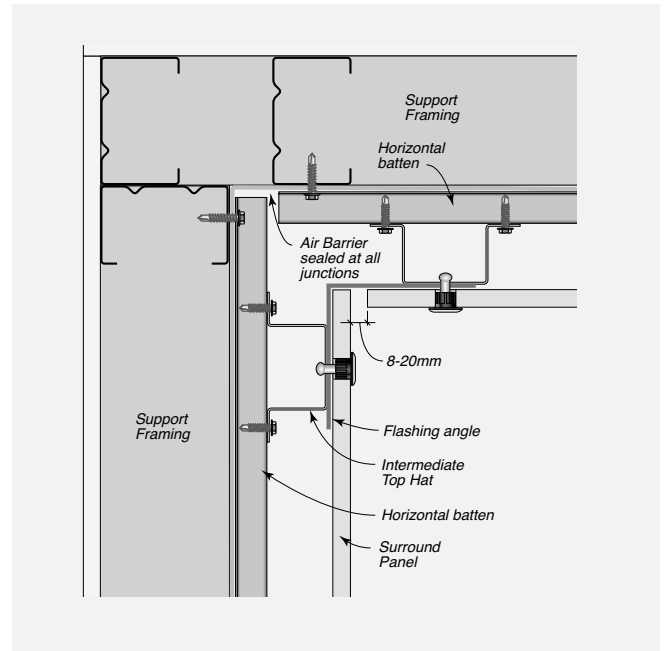

FIGURE 8.10 Internal Corner Detail





CONSTRUCTION DRAWINGS AND DETAILS

Note: Drawings are interchangeable for timber or steel substrates with the exception of the fasteners.

Pressure Equalised – Ventilated Cavity System

FIGURE 8.11 Framed Soffit

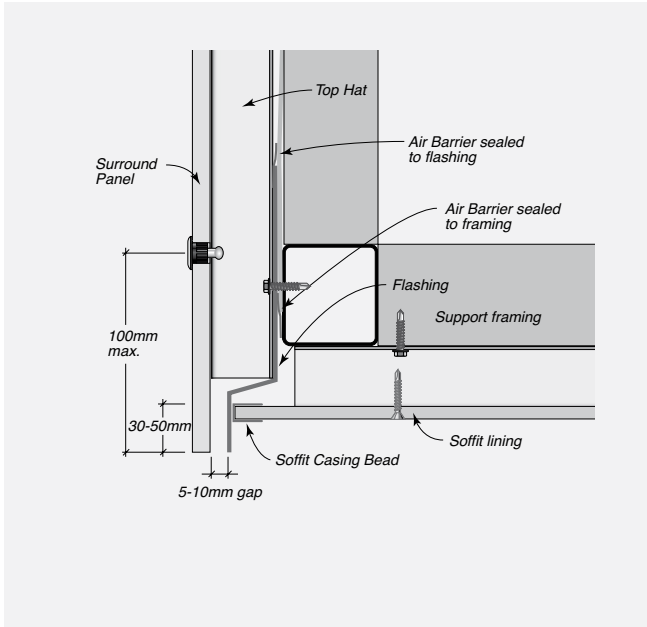

FIGURE 8.12 Control Joint – Vertical

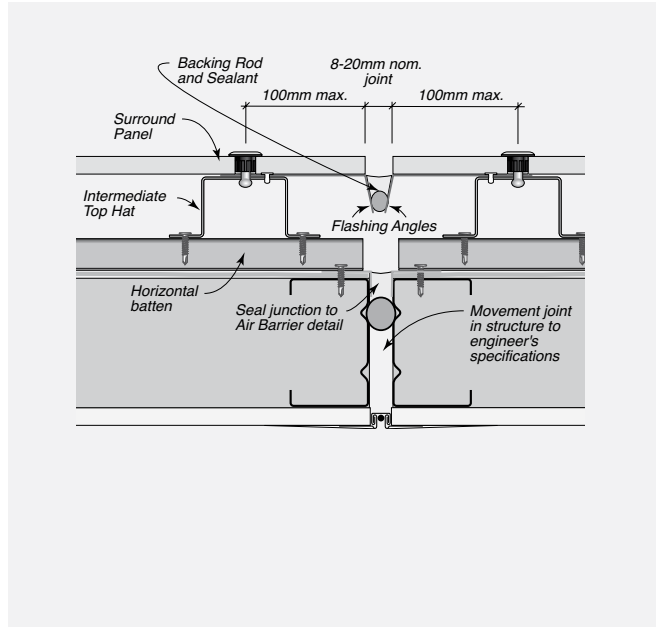

FIGURE 8.13 Inter-Storey Junction with Flashing

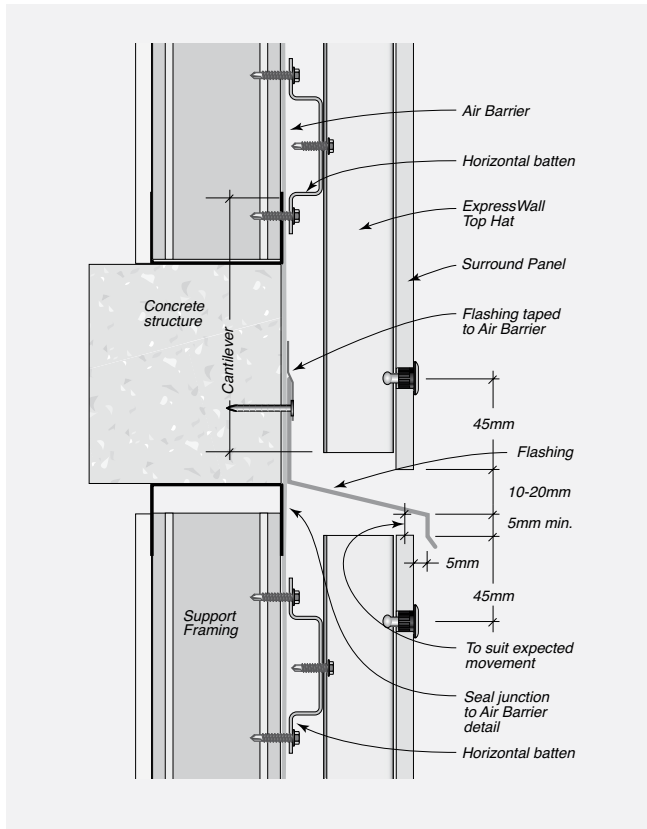
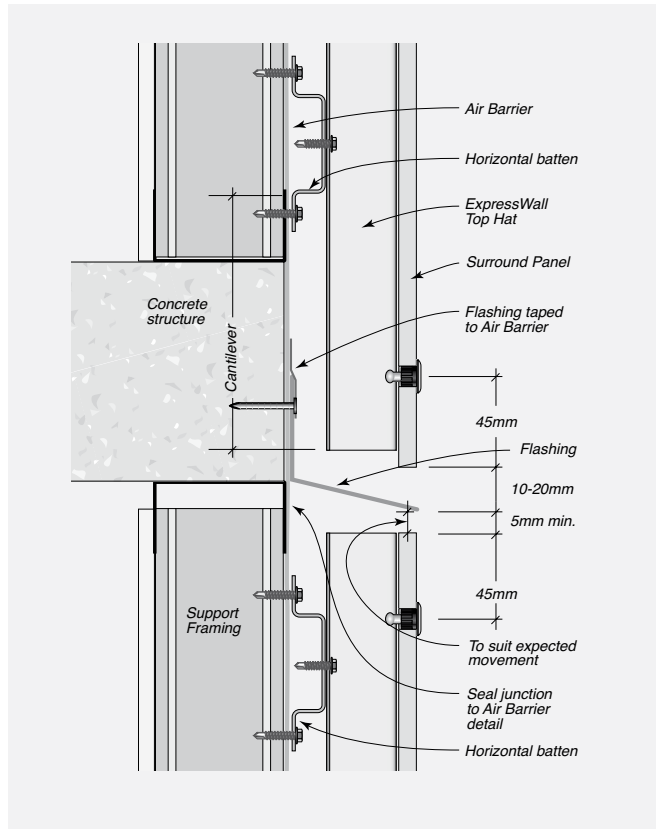

FIGURE 8.14 Inter-Storey Junction with Alternate Flashing



CONSTRUCTION DRAWINGS AND DETAILS



Note: Drawings are interchangeable for timber or steel substrates with the exception of the fasteners.

Pressure Equalised – Ventilated Cavity System

FIGURE 8.15 Inter-Storey Junction with Flashing

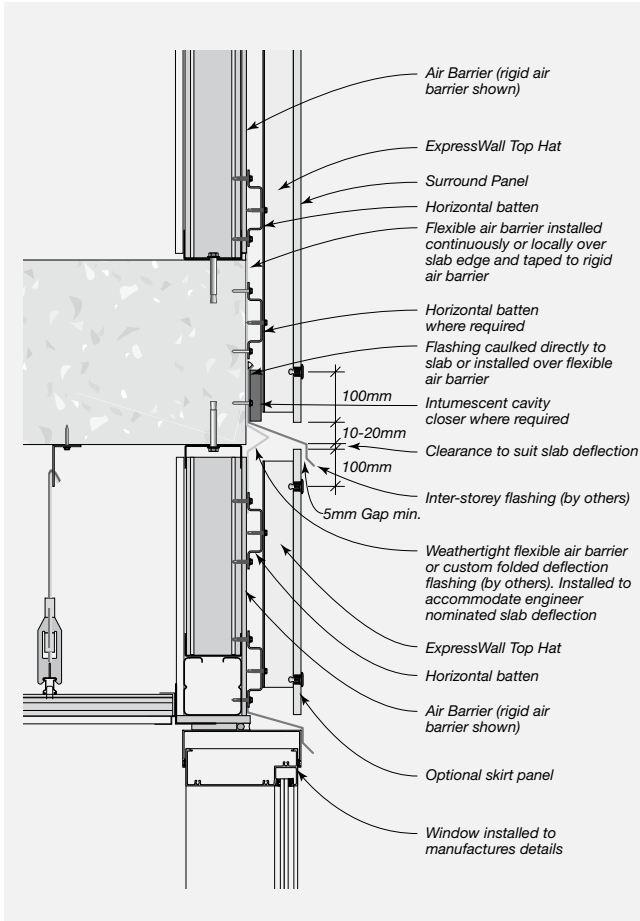
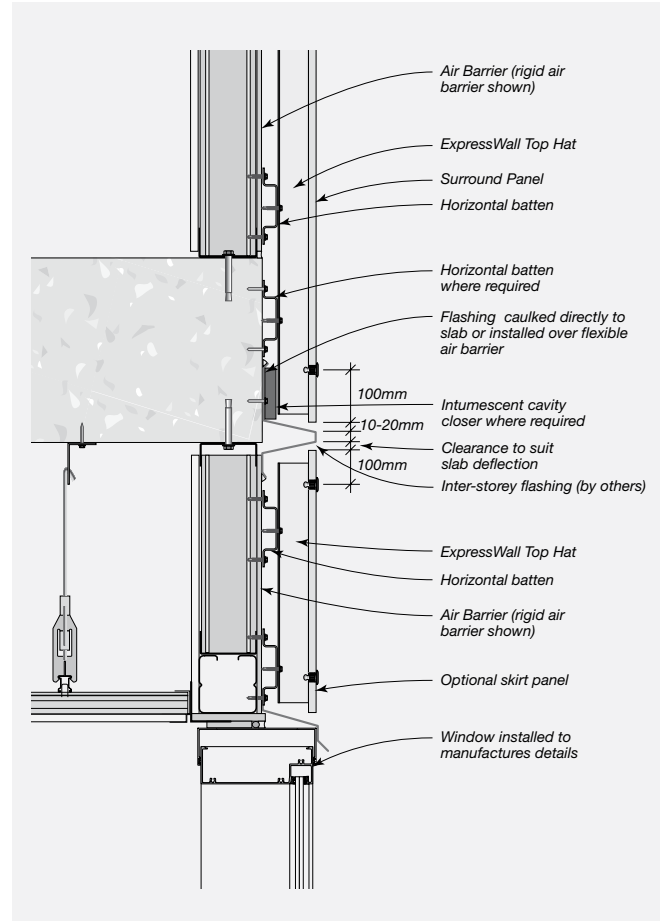

FIGURE 8.16 Inter-Storey Junction with Alternate Flashing





CONSTRUCTION DRAWINGS AND DETAILS

Note: Drawings are interchangeable for timber or steel substrates with the exception of the fasteners.

Pressure Equalised - Ventilated Cavity System

FIGURE 8.17 Abutment

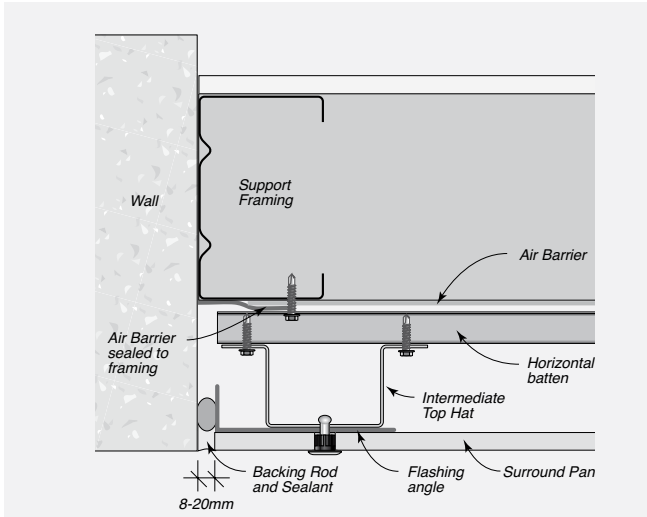

FIGURE 8.18 Vertical Gasket and Fixing Detail for Half-bond Panel Layout

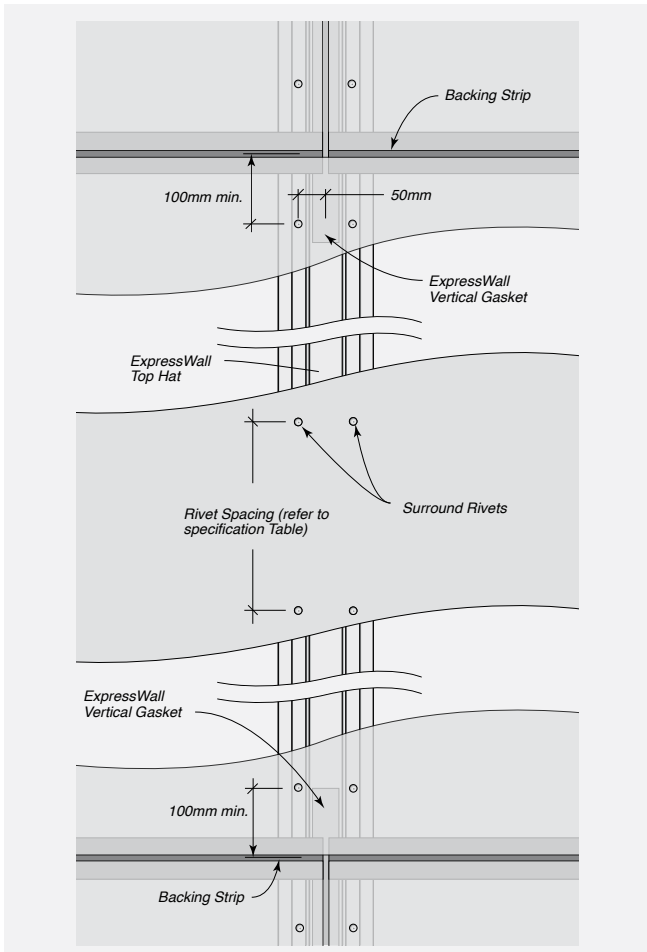
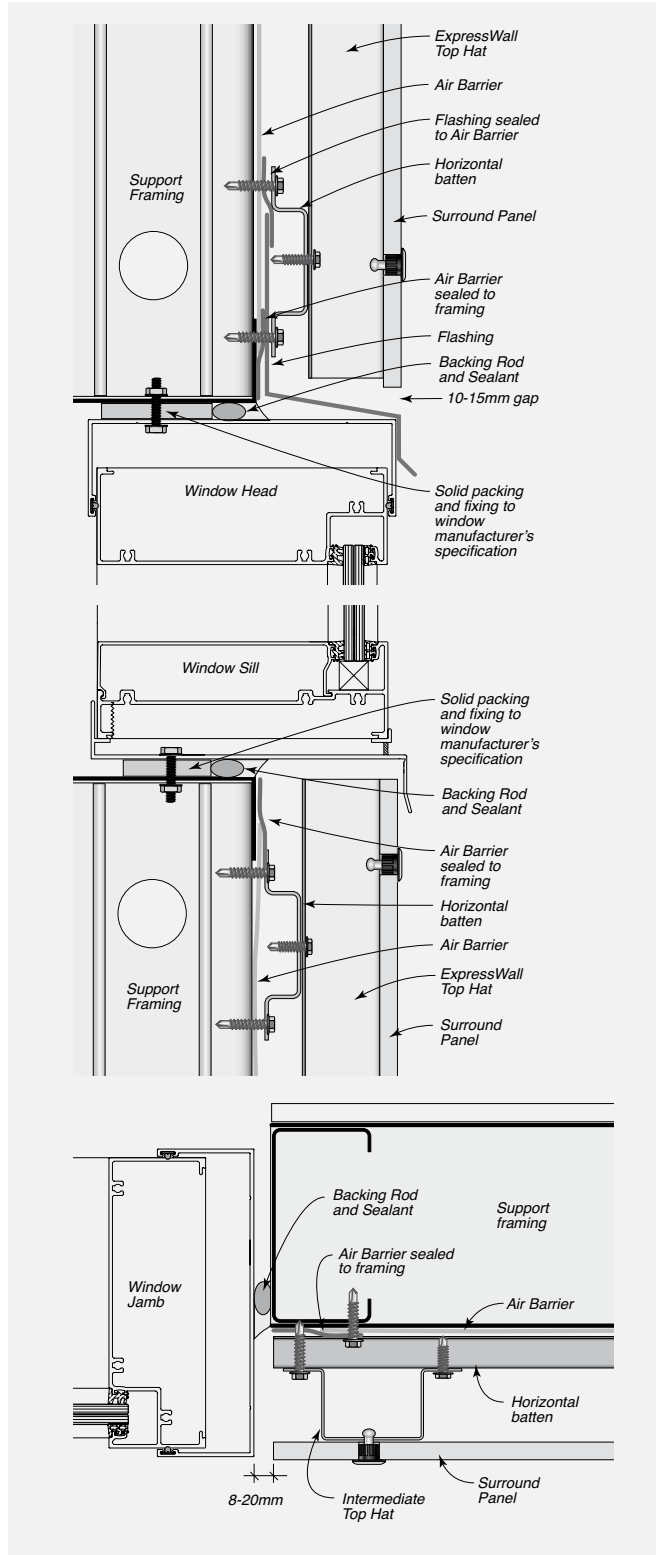

FIGURE 8.19 Typical Window Installation



CONSTRUCTION DRAWINGS AND DETAILS



Note: Drawings are interchangeable for timber or steel substrates with the exception of the fasteners.

Pressure Equalised – Ventilated Cavity System

FIGURE 8.20 Parapet Capping

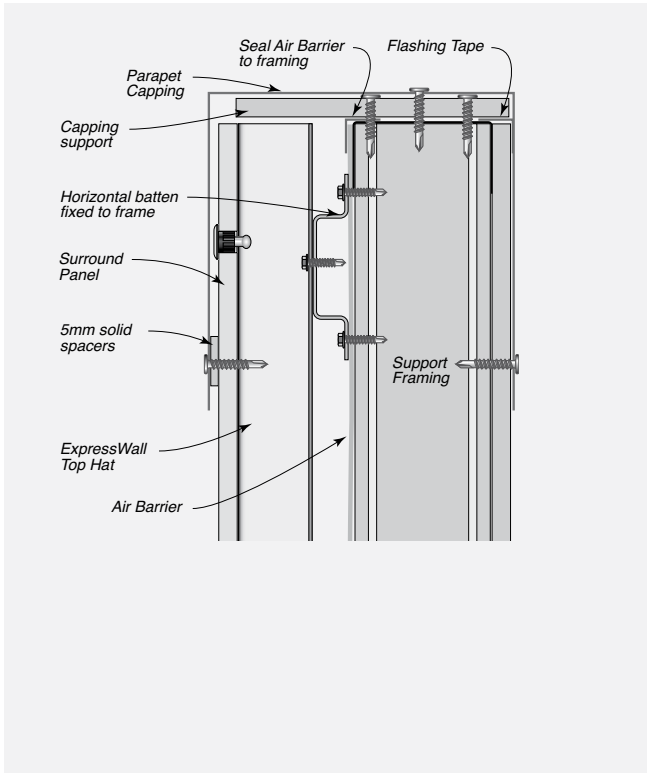

FIGURE 8.22 Typical Drain

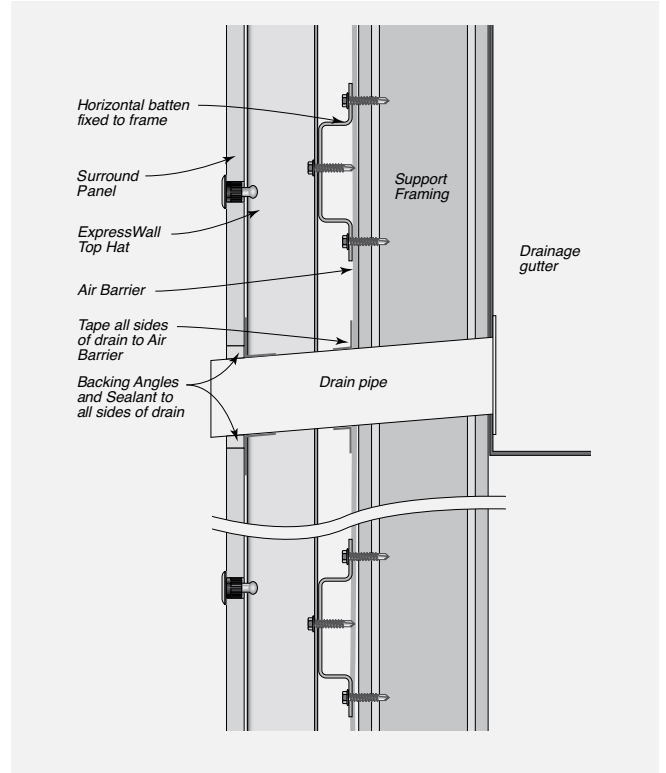
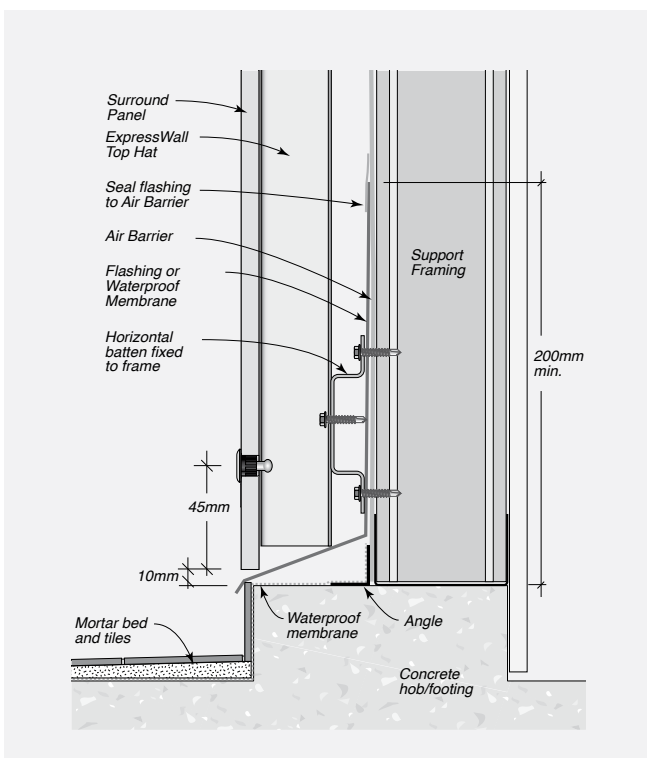

FIGURE 8.21 Balcony Base





CONSTRUCTION DRAWINGS AND DETAILS

Note: Drawings are interchangeable for timber or steel substrates with the exception of the fasteners.

Pressure Equalised – Ventilated Cavity System

FIGURE 8.23 Typical Power/Meter Box

Note: Refer to local authority for specific meter box installation requirements.

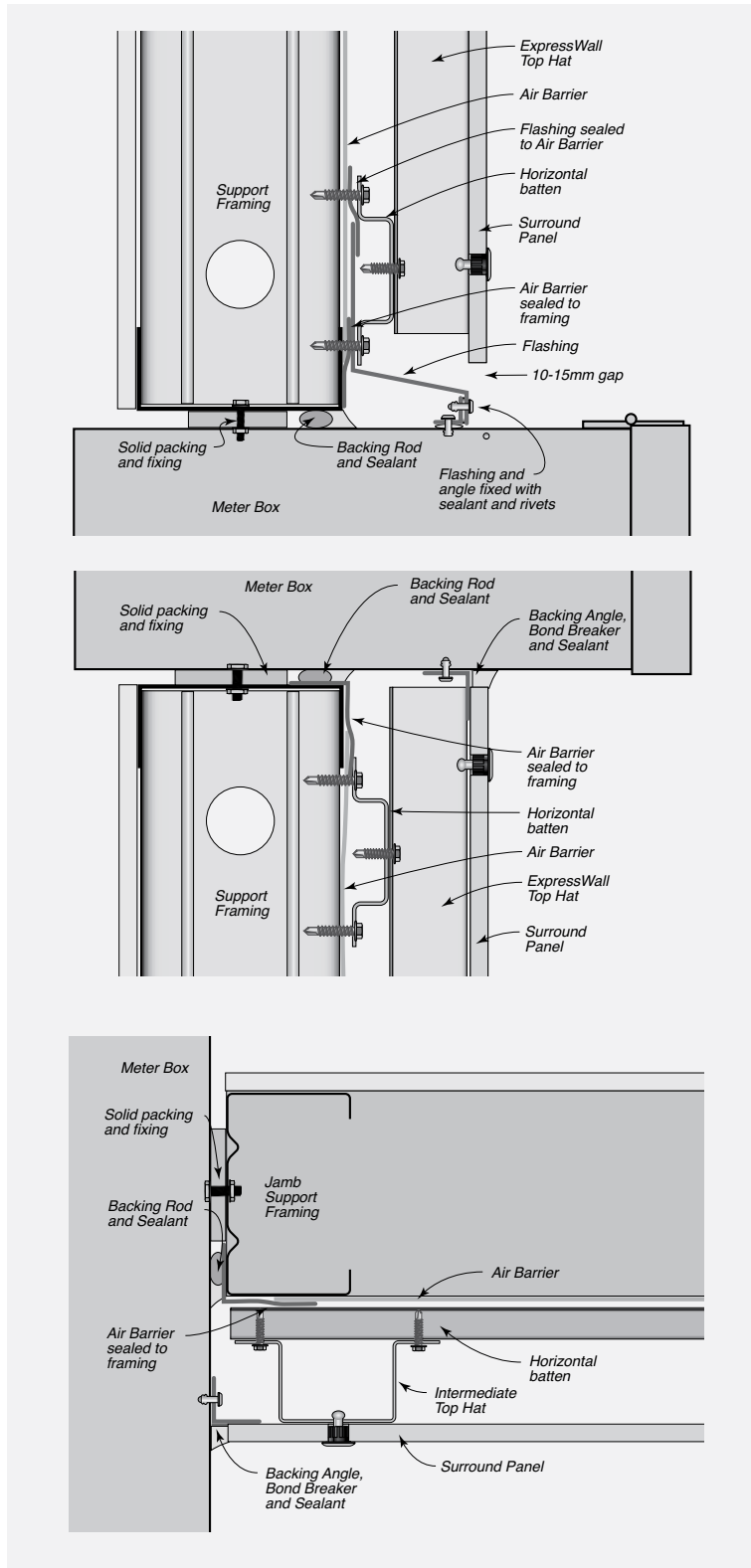

CONSTRUCTION DRAWINGS AND DETAILS



Note: Drawings are interchangeable for timber or steel substrates with the exception of the fasteners.

Pressure Equalised – Ventilated Cavity System – Sealant Filled Joint Details

FIGURE 8.24 Sealant Filled Joint Construction – Ventilated Cavity System

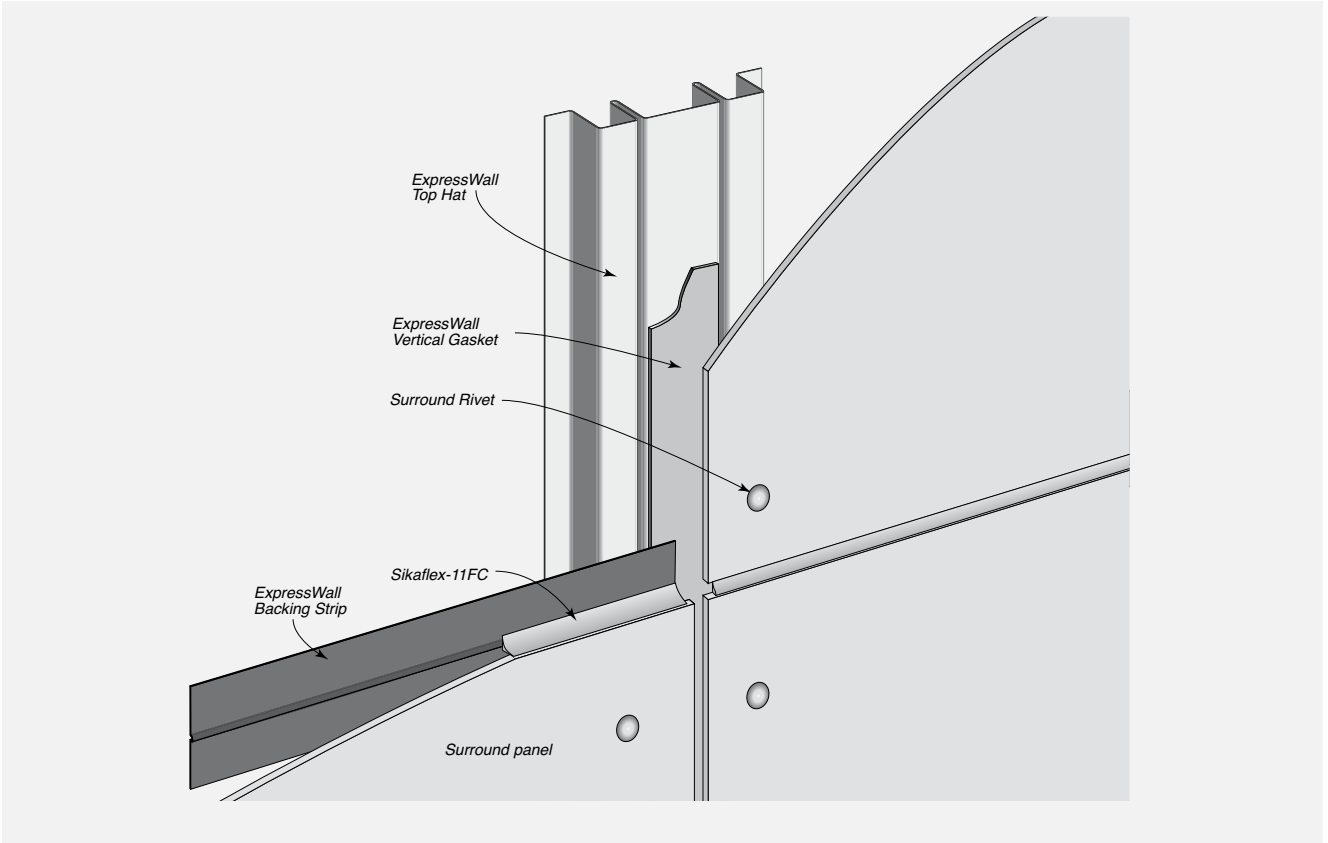

FIGURE 8.25 Backing Strip Preparation

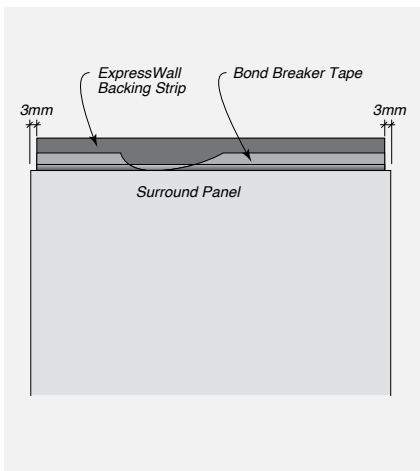

FIGURE 8.26 Horizontal Joint – Sealant filled

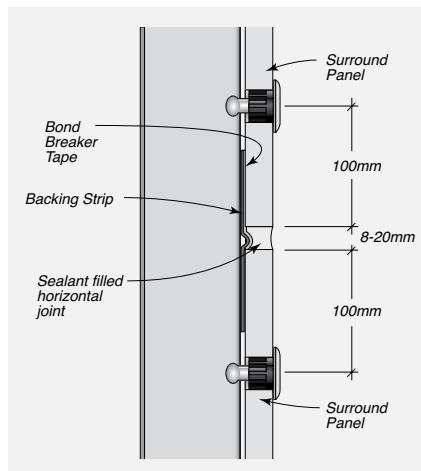
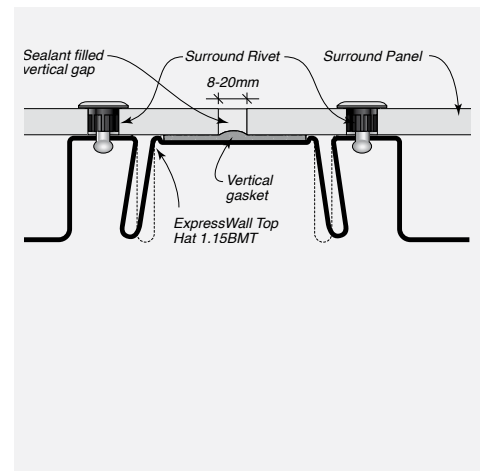

FIGURE 8.27 Vertical Joint – Sealant filled





CONSTRUCTION DRAWINGS AND DETAILS

Note: Drawings are interchangeable for timber or steel substrates with the exception of the fasteners.

Pressure Equalised – Ventilated Cavity System – Sealant Filled Joint Details

FIGURE 8.28 Typical ExpressWall System Cross Section for Steel Framing – Joints sealant filled

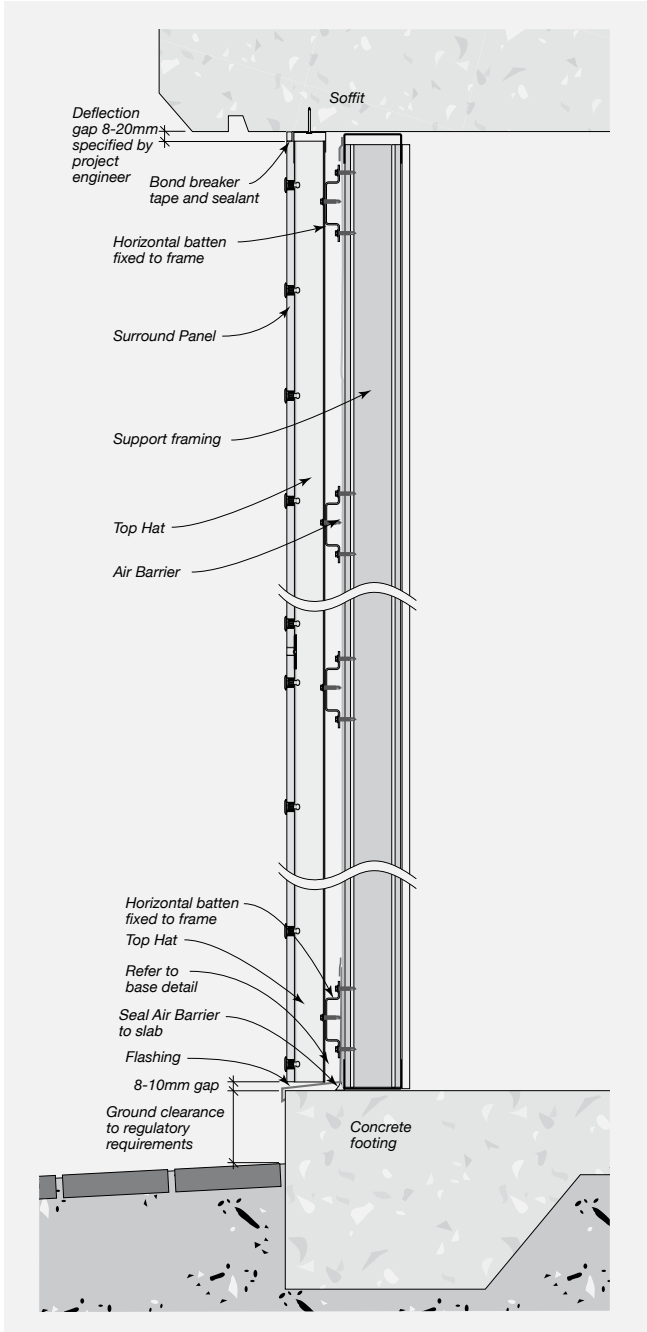

FIGURE 8.29 Eaves/Deflection Head – Sealant filled

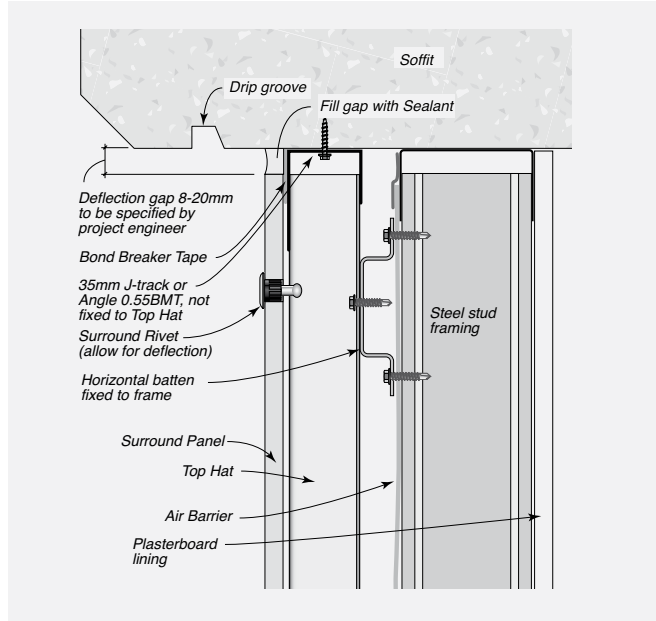
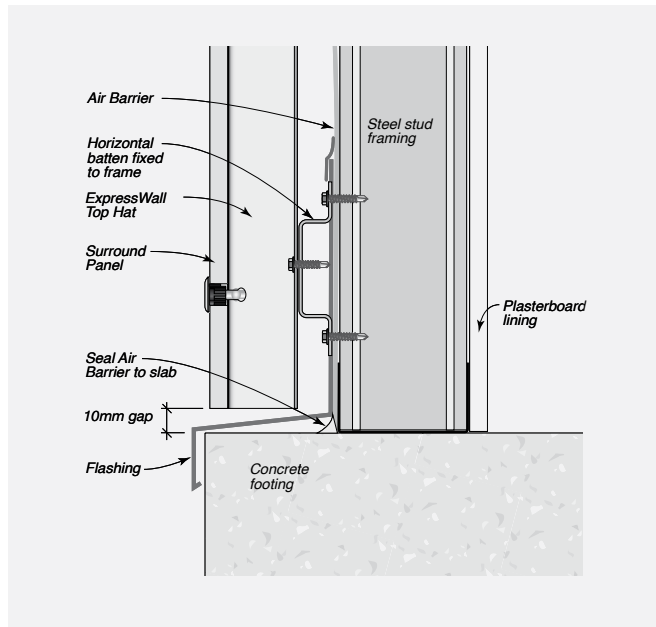

FIGURE 8.30 Base Detail – Drained



CONSTRUCTION DRAWINGS AND DETAILS



Note: Drawings are interchangeable for timber or steel substrates with the exception of the fasteners.

Pressure Equalised – Ventilated Cavity System – Sealant Filled Joint Details

FIGURE 8.31 Internal Corner Detail – Sealant filled

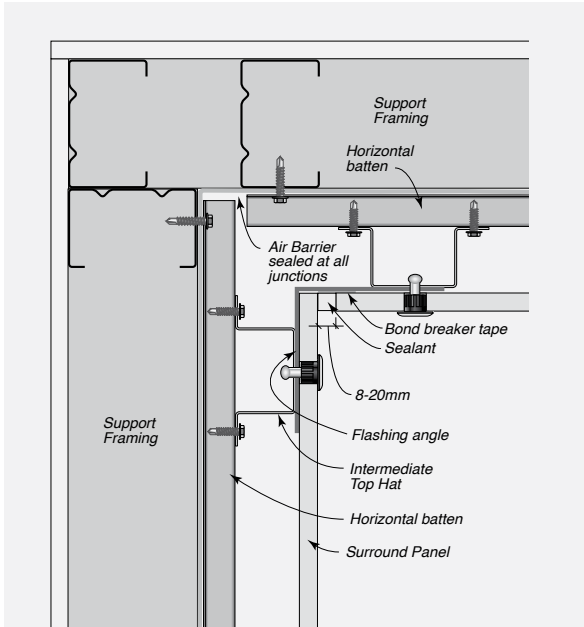
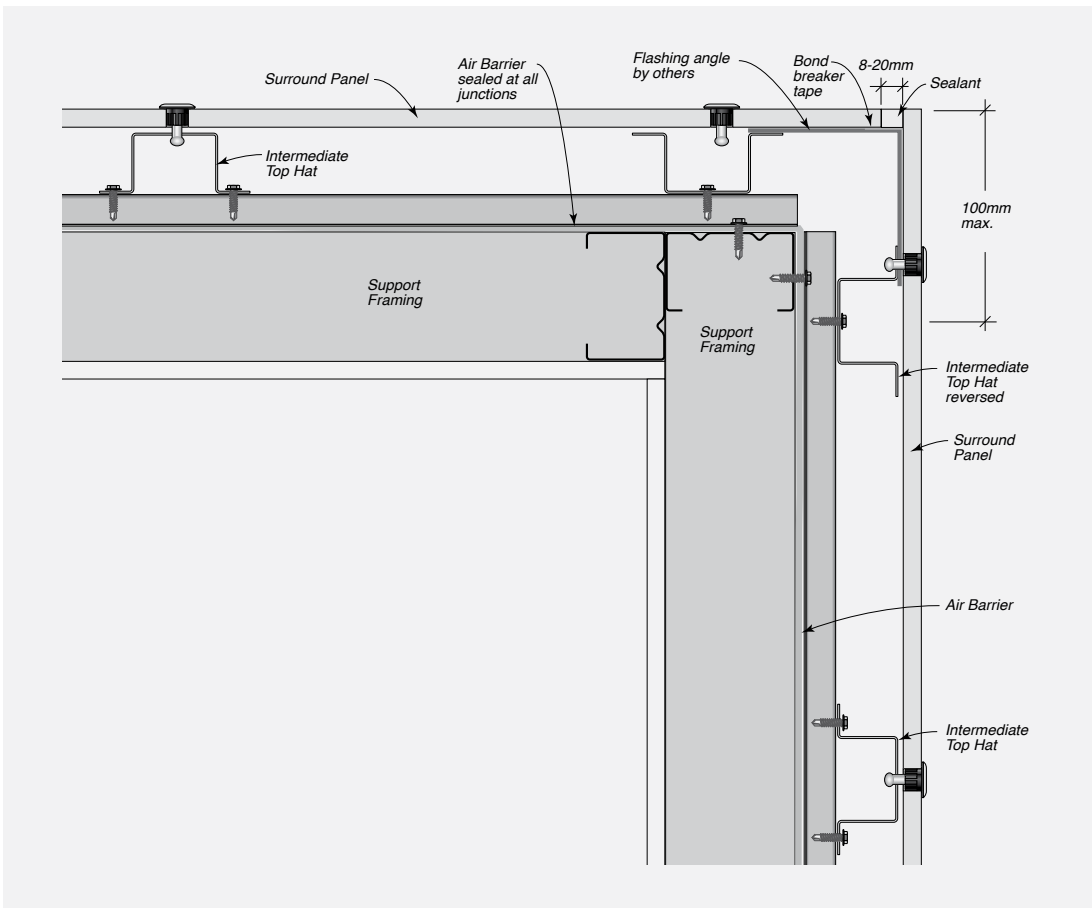

FIGURE 8.32 External Corner – Sealant filled





**SAFETY, HANDLING
+ GENERAL CARE**

SAFETY, HANDLING + GENERAL CARE



Health, Safety and Personal Protection Equipment (PPE)

Panels contain silicas that are harmful if inhaled. Protective clothing and breathing equipment must be worn when cutting products.

When cutting, drilling or grinding Surround panels using power tools, always ensure the work area is properly ventilated. An approved dust mask (AS 1715

and AS 1716) and safety glass (AS 1337) must be worn. Cemintel recommends that hearing protection also be worn.

Safety Data Sheet information is available at cemintel.com.au

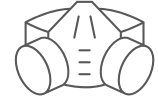

Recommended Safe Working Practices

Cutting Outdoors	<ol style="list-style-type: none"> 1. Position cutting station so wind will blow dust away from the user or others in the working area. 2. Use a dust reducing plunge saw equipped with a dust extraction system.
Sanding/Drilling/Other Machining	When sanding, drilling or machining, you should always wear a P1 or P2 dust mask and warn others in the immediate area.
Important Reminders	<ol style="list-style-type: none"> 1. NEVER use a power saw indoors. 2. NEVER use a saw blade that is not purpose-made for cutting fibre cement products. 3. NEVER dry sweep. 4. ALWAYS follow tool manufacturers' safety recommendations. 5. ALWAYS maintain tools in a clean condition.

Handling & General Care

Storage

All Surround panels must be stacked flat, clear of the ground and supported at 300mm maximum centres on a level platform. Panels must be kept dry, preferably stored inside the building. Panels must be dry prior to fixing, hence if it is necessary to store outside, the product must be protected from the weather.

Handling

Surround panels are prefinished products and must be treated with care during handling so as to avoid damage to edges, ends and prefinished surface. Panels should be carried horizontally on edge by at least two people.

As Surround external is a prefinished product, consideration should be given to the activity of other tradespeople, in particular, a brick cleaner. It is highly recommended that installation of Surround should always be held off until the process of brick cleaning has been completed so as to avoid damage.

Cutting

Panels should be cut from the back using a power saw. Cemintel recommends using the Makita Plunge Cut Saw with guide rail and appropriate blade, together with the appropriate dust extraction system.

All exposed cut edges **MUST BE SEALED TO PREVENT MOISTURE ABSORPTION**. Refer to 'Components' table for appropriate materials.

Mitres

It is not recommended to mitre panels as this can cause delamination of the face.

Penetrations

Penetrations in panels may be cut or drilled prior to installation. Cut from the back or drill from the front. Cut penetrations oversize by 8-10mm all around. Mask, prime and fill gaps with sealant in accordance with recommended methods and products.

Bevelled Edges

The top edge of panels at window sill level may require bevelling.

10
WARRANTY, CLEANING
+ MAINTENANCE

Warranty

The Cemintel Surround External panels have a product warranty of 10 years.

The full product warranty is available for download at cemintel.com.au

Wash Down Process

Panels have been coated with a factory finish. Consequently, where sufficiently exposed, rain can perform a natural wash down of the wall and ongoing maintenance should be limited to occasional rinse down or using a soft cloth or soft brush (like a dust pan brush).

Walls which are protected by soffits above must be washed down twice per year to remove salt and debris build up particularly at joints.

When cleaning the panels the following is recommended –

- Normal dirt can be removed with a soft brush and warm water up to 50 degrees celsius, to which a small amount of dishwashing liquid or soap has been added. The panels should be rinsed with clear water before they dry.
- Calcifications should be removed with a 5% sulfamic acid solution or with a commercial lime remover. The façade should be rinsed with clear water after cleaning.
- Panels discoloured by algal growth should be treated with an algicide without bleaching agents. This application should be allowed to take effect for several days. Afterwards, clean the panels using the 'normal dirt' procedure above.
- When rinsing down panels, use no more than 700 psi (50kh/cm²) of water pressure at a minimum of 3m distance from the face of the wall. Water pressure should be applied downward to avoid forcing water into joints.
- Use neutral detergent with a soft cloth or soft brush when removing dirty spots from a panel. When diluting the neutral detergent, follow the manufacturer's instructions and use the weakest solution possible.

Inspection, Repair and Maintenance

The durability of the Cemintel Surround range can be enhanced by periodic inspection and maintenance. Inspections should include examination of the coatings, flashings and seals. Any cracked or damaged finish or seals which would allow water ingress must be repaired immediately by resealing the affected area, or by removing the panel and replacing sealant. Any damaged flashings, sheets or sealant must be replaced as for new work.

Regularly inspect panel surfaces and follow wash-down procedures when required.

Ensure ventilation and drainage gaps between panels and flashings are clear of any debris.

It is recommended storing additional panels in case any panels are damaged in the future.



Our Offices

Brisbane

768 Boundary Road
Coopers Plains QLD 4108

Sydney

376 Victoria Street
Wetherill Park NSW 2164

Melbourne

277 Whitehall Street
Yarraville VIC 3013

Adelaide

Lot 100 Sharp Court
Mawson Lakes SA 5095

Perth

19 Sheffield Road
Welshpool WA 6106

Hobart

11 Farley Street
Derwent Park TAS 7009

Darwin

Cnr Stuart Highway &
Angliss Street
Berrimah NT 0828

cemintel.com.au
1300 236 468

For Design and Technical Support:
DesignLINK – 1800 621 117

Cemintel is a trading entity of CSR Building Products Limited (ACN 008 631 365).

Disclaimer: Information presented in this document is supplied in good faith and to the best of our knowledge, was accurate at the time of preparation. Products are subject to natural variation as part of the manufacturing process. Product images may vary from actual product in regard to colour and surface finish. The provision of this information should not be construed as a recommendation to use any of our products in violation of any patent rights or in breach of any statute or regulation. Users are advised to make their own determination as to the suitability of this information in relation to their particular purpose or specific circumstances. Since the information contained in this document may be applied under conditions beyond our control, no responsibility can be accepted by Cemintel, or its staff for any loss or damage caused by any person acting or refraining from action as a result of misuse of this information.